

**Argo 6x6**  
**BIGFOOT**



# **ARGO**

## **BIGFOOT**

### **PARTS MANUAL**

**Model Nos. V698-58**  
From Serial # ...B13784

# Foreword

ODG has prepared this parts manual for the BIGFOOT model to assist both qualified mechanics and vehicle owners in ordering correct, quality replacement ARGO parts.

Proper and regular service, and replacing old, worn or broken parts with the correct ARGO replacement parts, are both essential to prolonging the life of the ARGO. Please refer to this parts manual before ordering any replacement part.

All information contained in this BIGFOOT Parts Manual is based on the latest product specification available at time of printing. If your BIGFOOT differs from the specifications contained in this manual, contact Ontario Drive & Gear Limited for information.

ODG reserves the right to alter specifications on the BIGFOOT model at any time, without obligation or prior notification.

Reproduction of the BIGFOOT Parts Manual No. 698-58-5, in whole or in part, is prohibited without prior written permission from Ontario Drive & Gear Limited.

## Model Identification

**BIGFOOT** - Model No. V698-58

## Explanation of Parts Manual Format

<b>Ref</b>	- Reference number between assembly diagram and component parts list
<b>Part No.</b>	- Argo replacement part number for identification and re-ordering
<b>Description</b>	- Part description for identification and re-ordering
<b>Qty</b>	- Indicates the quantity of a part used in an Assembly

# ARGO 6x6 BIGFOOT



## Using the Parts Manual

1. Find the major vehicle assembly in the Table of Contents on this page, and turn to that section.
2. Locate the part in the illustration that you wish to order.
3. Refer to the parts list in that section.
4. Find the correct part number (Part No.), part description (Description) and correct quantity (Qty).
5. Use *only* this information to order ARGO replacement parts. *DO NOT* attempt to order a replacement part by reference number or page number.

## Table of Contents

Foreword .....	i
Model Identification .....	i
Using the Parts Manual .....	ii
1.0 Transmission .....	1
2.0 Intake and Exhaust System .....	3
3.0 Clutch System .....	4
4.0 Power Pack Assembly .....	5
5.0 Brake System - Hydraulic .....	7
6.0 Vehicle Body & Firewall .....	9
7.0 Frame & Drive System .....	11
8.0 Fuel System & Seat Assembly .....	13
9.0 Electrical System .....	15

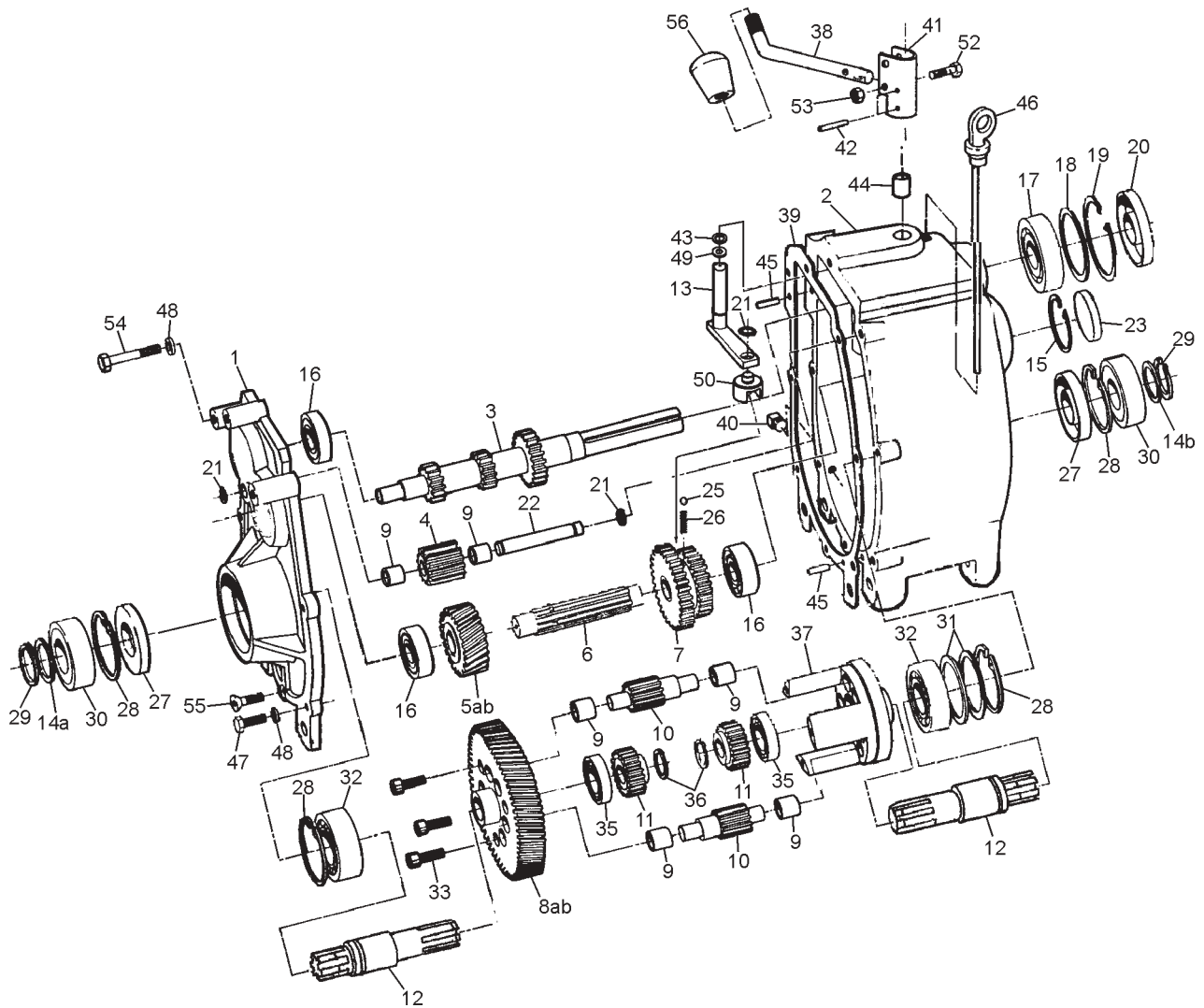

Ref.	Qty.	Part #	Description
.	1	610-18H	Transmission Asm - H,does not include Refs 38, 52, 53 & 56
1	1	34-68	Cover, Transmission
2	1	34-99	Housing, Transmission
3	1	34-21	Shaft, Input - 13/21T
4	1	34-16A	Gear, Idler 13T
5a	1	34-96	Gear, Helical - 26T-H
5b	1	34-95	Gear, Helical - 24T-M
6	1	34-94	Shaft, Spline
7	1	34-91	Gear, Double - 26/33T
8a	1	34-43	Gear Plate - 71T-H
8b	1	34-22	Gear Plate - 73T-M
9	14	105-03	Bushing, Oilite 1/2 x 3/4
10	6	34-13	Gear, Planet - 12T
11	2	34-14	Gear, Sun - 21T
12	2	34-98	Shaft, Output
13	1	34-65	Shifter Asm
14a	1	114-04	Washer, Shim .040 Thk
14b	1	114-05	Washer, Shim .020 Thk
15	1	106-01	Retaining Ring
16	3	101-01	Bearing, Ball 6204Z-C3
17	1	101-16	Bearing, Ball 6206-C3
18	as req.	114-02	Washer, Shim 2.06x2.42x.02
19	1	106-05	Retaining Ring
20	1	102-05	Seal, Oil WBS 30x62x10
21	3	107-05	Retaining Ring
22	1	34-11	Pin, Dowel 1/2 x 3.50
23	1	31-07	Plug Plate
25	1	109-05	Ball, Steel 6mm 62-67 Rc
26	1	34-32	Spring, Compression - 7/32 x 0.50
27	2	102-03	Seal, Oil WBS 30x72x10
28	4	106-03	Retaining Ring
29	2	107-02	Retaining Ring
30	2	101-05	Bearing, Ball 6306-2NSE C3
31	2	114-01	Washer, Shim 2.25x2.81x.02
32	2	101-03	Bearing, Ball 6207-C3
33	3	103-04	SHCS 5/16-18 x 1.0 Bare
35	2	101-15	Bearing, Ball 6005-C3
36	2	107-04	Retaining Ring
37	1	34-08	Cage
38	1	610-77	Lever, Shift
39	1	34-47	Gasket, Cover - 1/64"Thk
40	1	103-02	Plug, Magnetic 3/8 - 18 NPT Sq. Hd.
41	1	34-86	Holder, Shift Lever
42	2	111-01	Pin, Spring 5/32 x 1.00 - Slotted
43	1	113-01	O-Ring
44	1	105-02	Bushing, Oilite 1/2x 1.0
45	2	104-03	Pin, Dowel 1/4 x 7/8
46	1	34-77	Dipstick - with Breather
47	4	103-06	HHCS 5/16-18x1.0 GR5 Zn
48	7	108-05	Lockwasher 5/16 Zn
49	1	108-74	Washer .64 x .875 x .10 Zn
50	1	34-63	Shift Yoke
52	1	103-97	HHCS 1/4-20x1.25 GR5 Zn
53	1	117-27	Locknut, Nylon 1/4-20 Zn
54			<b>See Section 4.0 Power Pack Assembly</b>
55	1	103-95	FHSC 5/16-18x1.0 GR8 Zn
56	1	126-38	Knob, Shift

## 2.0 Intake and Exhaust System

## Bigfoot Parts Manual

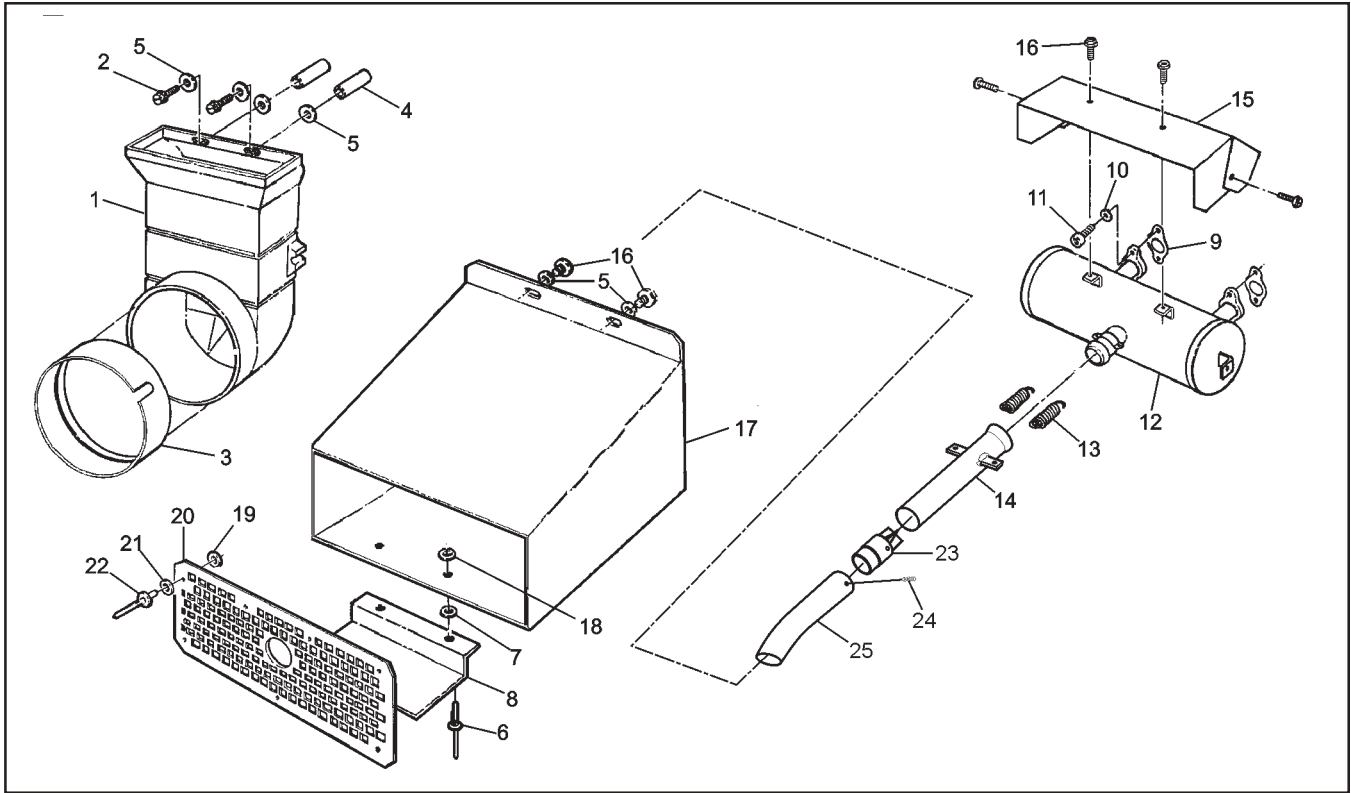

Ref.	Qty.	Part #	Description
1	1	603-81	Duct, Intake
2	2	112-48	Screw, T/S HH#14x2.25 Zn
3	1	603-82	Seal
4	2	120-29	Spacer, .26 ID x 1.12 LG
5	6	108-08	Washer, .28 x .62 x .04 Zn
6	2	120-13	Rivet 3/16 x 5/8 - Black
7	2	125-58	Washer, Fibre - W-77F
8	1	707-28	Support, Exhaust Duct
9	2	805024	Gasket
10	4	108-02	Lockwasher 5/16 Hi-Collar Bare
11	4	112-30	SHCS M8x1,25x20mm Zn
12	1	807-90	Muffler, B&S V-Twin Weld Ass'y
13	2	126-57	Spring, Extension- 7/16x2.14
14	1	807-92	Pipe, Mufflertail - B&S
15	1	807-85	Shield, Muffler Heat
16	6	112-19	Screw, IHWH T/C Slot 1/4-20x1/2
17	1	707-32	Duct, Exhaust
18	2	120-04	Washer .19x.50x.08 Zn
19	7	120-05	Washer .19x.50x.04 Zn
20	1	707-31P	Screen, Exhaust
21	7	125-59	Washer, Fibre -.062x.25x.50
22	7	120-09	Rivet 3/16 x 1 - Black
23	1	807-67	Spark Arrester
24	1	112-43	Screw, IHWH #8x3/8
25	1	807-89	Tube, Tailpipe Outlet

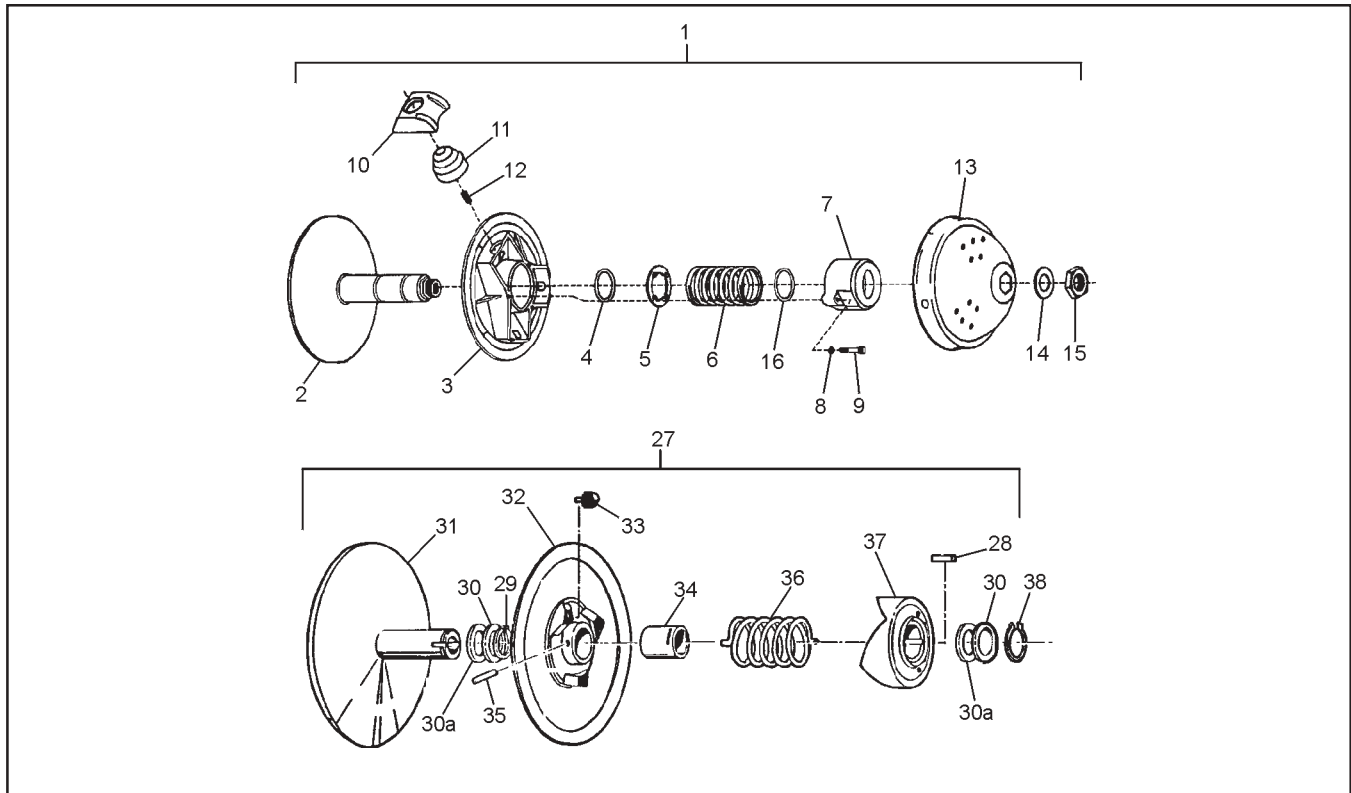

Ref.	Qty.	Part #	Description
1	1	127-73	Clutch, Driver (incl. Refs 2-15)
2	1	0405-0043	Pulley, Fixed half
3	1	0410-0007	Pulley, Sliding half
4	1	V08	Retaining Ring
5	1	V09	Plate, Spring Guide
6	1	V10-48-103-18	Spring
7	1	0440-0001	Cover, Spring
8	3	420-2453-700	Washer, Lock
9	3	222-9640-66	SHCS
10	3	0130-3002	Block, Red
11	3	C13-225	Weight, Lead 225g
12	3	C24-L1	Spring, Anti-noise
13	1	0115-0003(A)	Cap
14	1	0080-0153	Washer Zinc
15	1	0080-0100	Nut
16	1	V08C	Spring Ring
27	1	126-24	Clutch, Driven - Model "B" (incl. Refs 28-37)
28	1	ASK-5	Key 1/4 x 1/4 x 5/8
29	1	ASR-6	Retaining Ring
30	as req	ASA-1	Spacer .050" Thick
30a	as req	ASA-1-S	Spacer .025" Thick
31	1	AFK25.4-250OD01	Pulley, Half - Fixed
32	1	AMC-2-250OD01	Pulley, Half - Sliding incl. Refs. 33, 34 and 35
33	3	ANS-2-T	Shoe, Cam
34	1	AMB-2	Bushing, Bronze
35	1	111-01	Pin, Spring 5/32 x 1.00 - Slotted
36	1	ACS-3-188	Spring, Blue
37	1	AFC-4-C3D4	Cam
38	1	371-9031-000	Retaining Ring

# 4.0 Power Pack Assembly

# Bigfoot Parts Manual

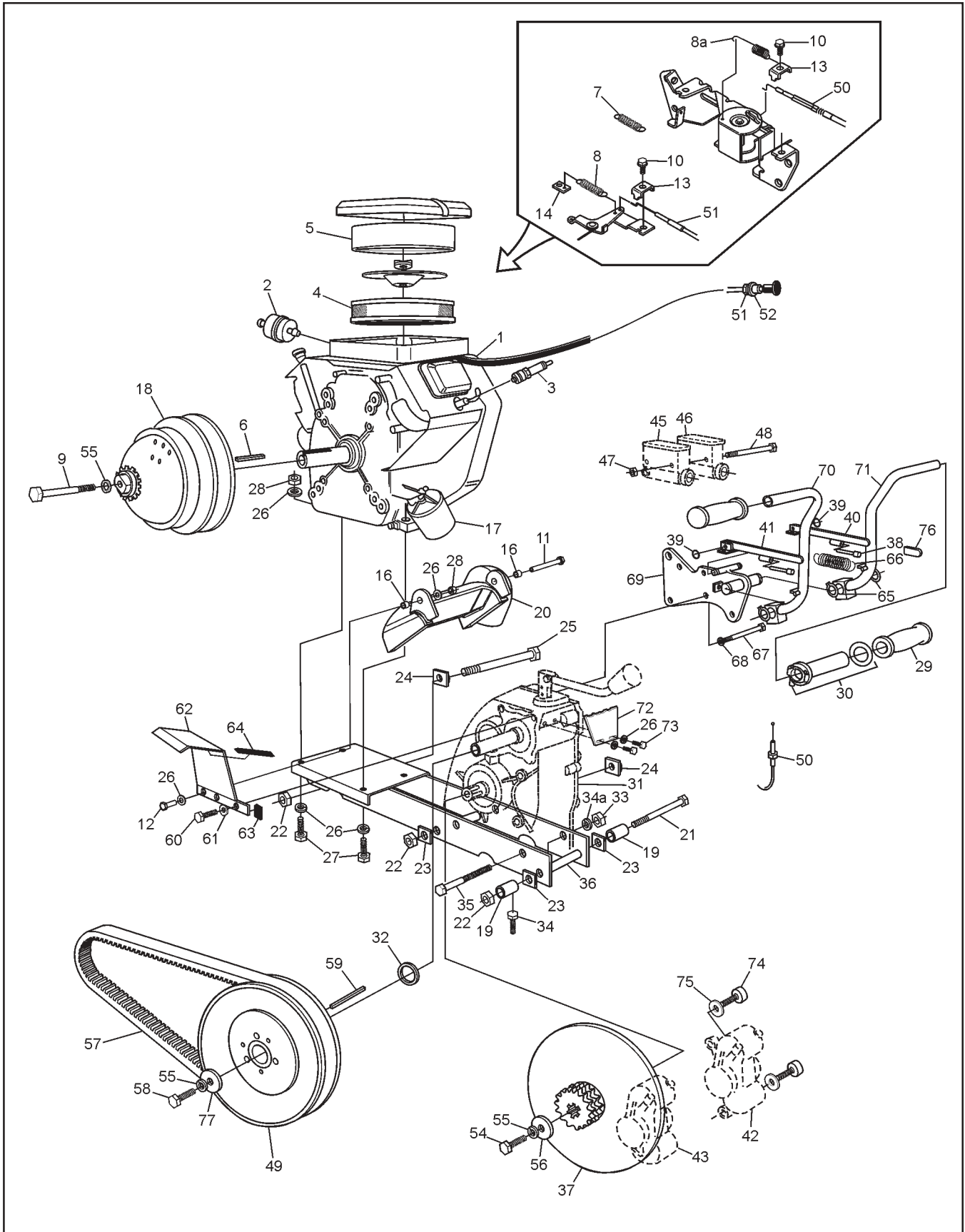



# Bigfoot Parts Manual

# 4.0 Power Pack Assembly

Ref.	Qty.	Part #	Description	Ref.	Qty.	Part #	Description
1	1	127-53	Engine - Vanguard 18HP incl Refs 2,3,4,5,10,13,17 B&S #3504471282E1	37	2	610-80	Brake Disc - #50-2 x 13T
2	1	125-64	Fuel Filter	38	2	103-69	SHCS 1/4-20 x 1.5 Zn
3	2	126-74	Spark Plug #3926	39	2	113-02	O-Ring
4	1	394018	Filter, Air	40	1	810-21	Lever Asm, Brake - RH
5	1	272490	Element, Foam	41	1	810-20	Lever Asm, Brake - LH
6	1	110-03	Key 1/4x3/16x2.375 RC46	42 to 46			<b>See Section 5.0 Brake System</b>
7	1	805458	Spring	47	2	117-27	Locknut, Nylon 1/4-20 Zn
8	1	125-88	Spring, Return	48	2	103-66	HHCS 1/4-20x4.0 GR5 Zn
8a	1	127-49	Spring, Return	49			<b>See Section 3.0 Clutch System</b>
9	1	112-28	HHCS 3/8-24x4.5 GR5 Zn	50	1	612-101	Cable Asm, Throttle
10	2	805169	Screw-Hex Head (Briggs #)	51	1	117-68	Nut, Jam 3/8-24 UNF Zn
11	1	112-132	HHCS 5/16-18x3.25 GR5 Zn	52	1	108-32	Lockwasher 3/8 Int. Tooth
12	1	103-38	HHCS 5/16-18X1.25 GR5 Zn	54	2	103-18	HHCS 3/8-24x1.25 GR5 Zn
13	2	805170	Clamp - Casing (Briggs #)	55	4	108-06	Lockwasher 3/8 Zn
14	1	601-86	Clip, Retainer	56	2	108-18	Washer .40x1.37x.12 Zn
16	2	108-71	Spacer, 5/16 ID x 7/16 OD x 13/32 LG	57	1	125-56	Drive Belt
17	1	126-95	Filter, Oil	58	1	103-34	HHCS 3/8-16x1.25 GR5 Zn
18			<b>See Section 3.0 Clutch System</b>	59	1	110-09	Key 1/4 x 1/4 x 3.0
19	2	811-14	Spacer	60	2	103-17	HHCS 3/8-16x1.0 GR5 Zn
20			<b>See Section 5.0 Brake System</b>	61	2	108-26	Washer 3/8 Zn
21	1	112-57	HHCS 5/8-11x10.0 GR5 Zn	62	1	603-29	Guard, Belt Protect
22	3	117-09	Locknut, Nylon 5/8-11 Zn	63	1	601-92	Trim, Vinyl - 1.5"
23	3	811-09	Washer, Square .64 ID	64	1	601-93	Trim, Vinyl - 4.25"
24	2	811-15	Washer, Square Lock .64 ID	65	4	106-07	Retaining Ring
25	2	112-58	HHCS 5/8-11x7.5 GR5 Zn	66	2	127-33	Spring, Extension
26	14	108-24	Washer 5/16 SAE Zn	67	2	103-55	HHCS 5/16-18x2.75 Gr5 Zn
27	4	112-27	HHCS 5/16-18x1.75 Gr5 Zn	68	3	108-05	Lockwasher 5/16 Zn
28	5	117-21	Locknut, Nylon 5/16-18 Zn	69	1	850-61	Bracket Asm, Steering
29	2	127-35	Grip, Molded Rubber	70	1	812-27	Lever Asm, Steering - LH
30	1	127-81	Throttle Twist Grip	71	1	812-26	Lever Asm, Steering - RH
31			<b>See Section 1.0 Transmission</b>	72	1	610-81	Shift Gate, Transmission
32	as req	108-36	Washer 1.03x1.37x.06 Zn	73	2	112-01	HHCS 5/16-8x3/4 Gr5 Zn
33	2	117-06	Nut, Fin Hex 1/2-13 Zn	74	4	103-41	SHCS 3/8-16 x 1.25 Zn
34	2	103-53	HHCS 3/8-16x3.0 Full Thread	75	4	108-23	Washer 3/8 SAE Gr8 - Dich.
34a	2	108-07	Lockwasher 1/2 Zn	76	2	126-89	Cap, Vinyl - Black
35	2	103-20	HHCS 1/2-13x6.5 GR5 Zn	77	1	108-46	Washer .40 x 1.37 x .12 Hi-Carbon
36	1	611-71	Frame, Power Pack				

# 5.0 Brake System - Hydraulic

# Bigfoot Parts Manual

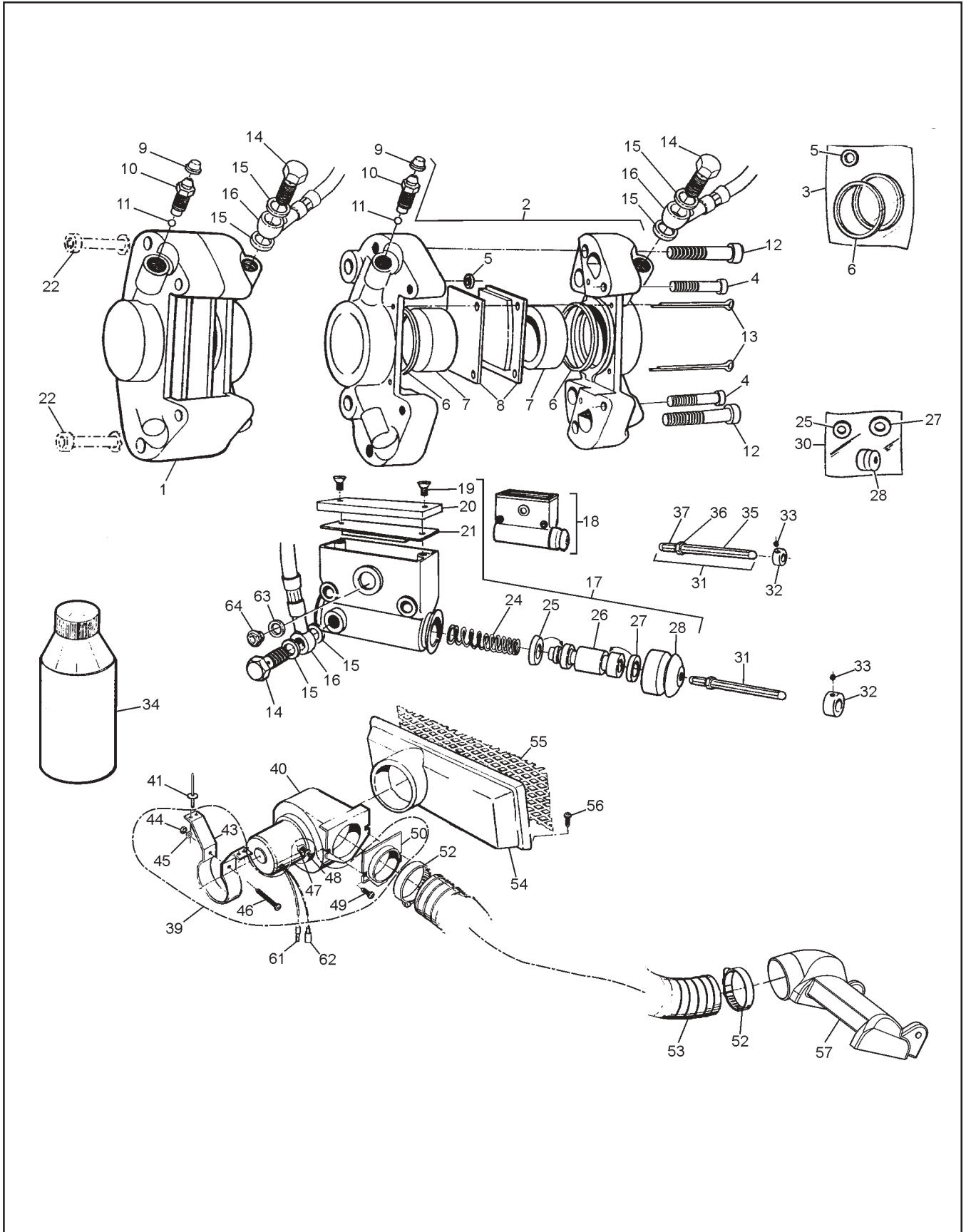

Ref.	Qty.	Part #	Description
1	1	166-01RM	Caliper, Brake-L w/o pads (incl. Refs 5,6,7,9-12)
2	1	166-02RM	Caliper, Brake-R w/o pads (incl. Refs 5,6,7,9-12)
3	2	161-01	O-Ring Kit, Caliper (incl. Refs 5 & 6)
4	2	160-40	SHCS M8 x 1,25 x 40 Zinc
5	1		Seal, Rubber-5mm (see Ref 3)
6	2		Seal, Piston-41mm (see Ref 3)
7	2x2	168-05	Piston 41mm
8	1	170-01	Brake Pad Set (4)- Non-asbestos
9	1x2	168-20	Plug, Rubber
10	1x2	168-03	Screw, Bleeding M10 x 1,0
11	1x2	109-03	Ball, Steel - 7/32 Dia.
12	2x2	160-41	SHCS M10x1,5x50mm Zn
13	2x2	168-06	Pin, Cotter 3,2 x 50mm
14	4	160-44	Bolt, Banjo-M10x1,0x21,0 Zn
15	8	160-01	Washer, Copper
16	1x2	163-01	Hose Asm, Hydraulic-300mm
17	1	165-06	Master Cylinder -left (incl. Refs 19 to 21, 24 to 28, 63 & 64)
18	1	165-05	Master Cylinder - right (incl. Refs 19 to 21, 24 to 28, 63 & 64)
19	2x2	160-42	FHMS M5 x 0,8 x 6mm
20	1x2	168-08	Cover
21	1x2	168-09	Cover, Rubber
22			<b>See Section 4.0 Power Pack Assembly</b>
24	1x2	162-02	Spring, comp. 0.59 x 1.5
25	1x2		Seal, Primary,19mm (See Ref. 30)
26	1x2	168-10	Piston 19mm Dia.
27	1x2		Seal, Secondary, 19mm (See Ref. 30)
28	1x2		Boot, Rubber (See Ref. 30)
30	1x2	161-25	O-Ring Kit-Master Cylinder (incl. Refs 25, 27 & 28)
31	2	812-13	Pin Asm, Plunger-Adjustable
32	2	812-17	Collar
33	2	112-02	SHSS 10-24x1/4 Knurl Cup Pt,PL
34		126-19	Fluid, Brake-Silicon Dot 5
35	1	812-14	Pin, Female
36	1	117-20	Nut, Fin Hex 1/4-20 Zn
37	1	812-15	Fin, Male
39	1	125-92	Adpt. & Mounting Kit - Fan (incl. Refs 43 to 50)
40	1	125-91	Blower Fan
41	4	120-13	Rivet 3/16x5/8 - Black
43	1		Mounting Bracket
44	1		Nut, #10-32
45	1	See	Lockwasher, 3/16"
46	1	Ref. 39	Screw, #10-32 x 2"
47	2	Above	Nut, 1/4-20
48	2		Lockwasher, 1/4"
49	2		Screw, 1/4-20 x 5/8"
50	1		Adaptor, 3" Dia.
52	2	125-35	Clamp, Gear 3.50" HF-52
53	1	127-44	Hose, Intake 3" dia. x 46"
54	1	601-89	Intake Flange (specify colour)
55	1	126-61	Intake Screen
56	4	112-56	Pan HD Phil T/S #10x3/4 A Zn
57	1	128-01	Brake Cool Air Duct
61	1	118-02	Terminal, Male
62	1	118-03	Terminal, Female
63	1x2	160-03	O-Ring, Oil Window
64	1x2	168-14	Oil Window, Master Cylinder

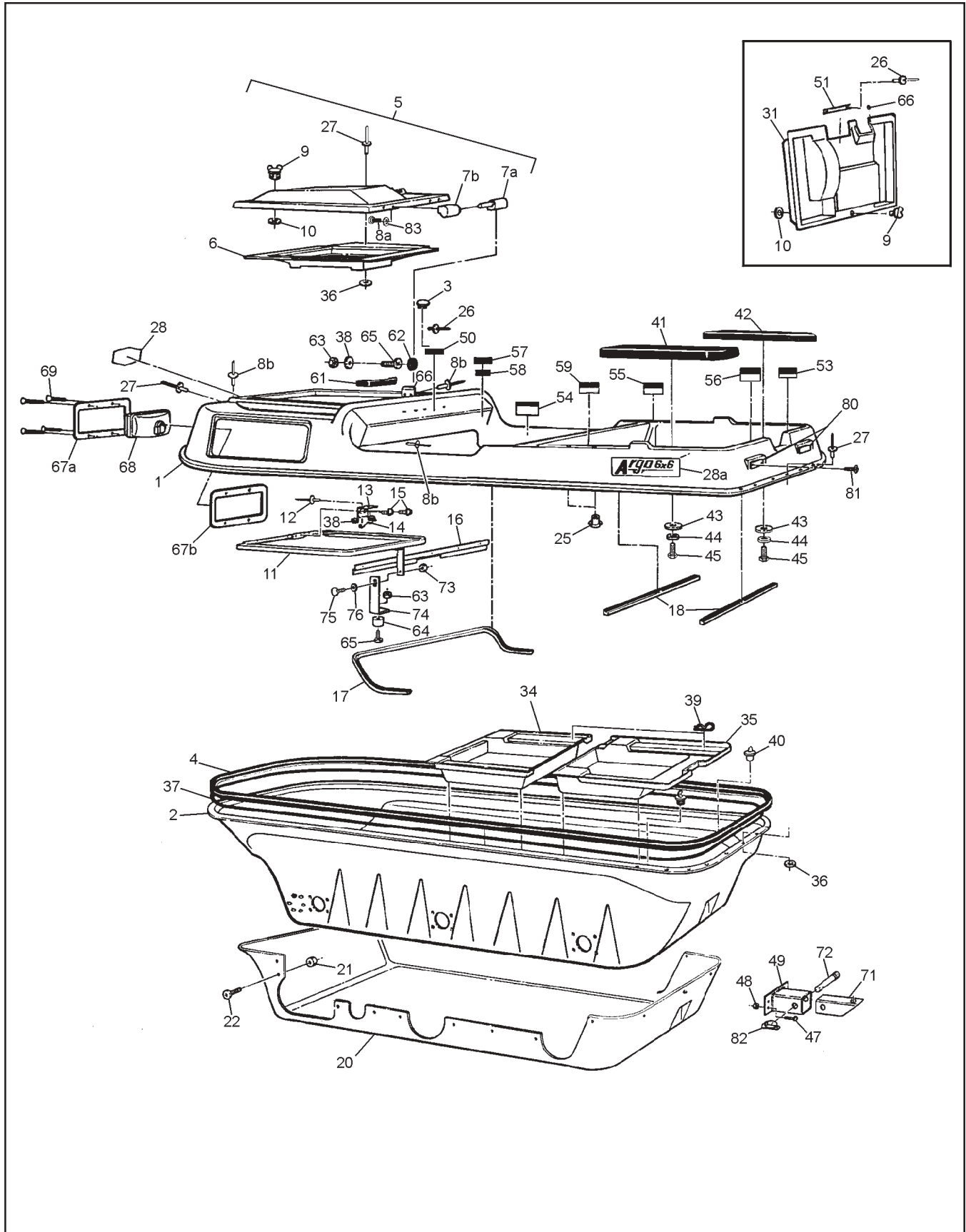

# Bigfoot Parts Manual

# 6.0 Vehicle Body & Firewall

Ref.	Qty.	Part #	Description
1	1	601-32	Body & Hood, Upper - Bigfoot Replacement, specify colour (incl. Ref 5, 11, 12, 13, 14, 15 & 38)
2	1	603-92	Body, Lower - Ext'd 6x6, specify colour
3	1	127-28	Plug, Nylon - Black
4	1	601-05	Bumper, Vinyl - 6x6
5	1	602-37	Hood Kit (specify colour) (incl. Ref 6 to 10, 27, 36, 66 & 83)
6	1	801-47	Duct, Intake Transition (specify colour)
7a	2	127-45A	Pin, Hinge
7b	2	127-45B	Knuckle, Hinge
8a	8	103-47	HHCS 10-24x1/2 Zn
8b	12	120-13	Rivet 3/16 x 5/8 - Black
9	2	126-10	Wing Stud
10	2	126-09	Grommet, Alum.
11	1	602-24	Hood Frame Assembly
12	2	120-15	Rivet 1/8 x 7/16
13	1	601-69	Spring Plate
14	1	126-11	Spring
15	2	112-19	Screw, IHWH T/C Slot 1/4-20x1/2
16	1	602-29	Brace, Dash
17	1	601-08	Vinyl Trim, 84"
18	2	601-09	Vinyl Trim, 28"
20	1	663-11	Skid Plate - Ext'd 6x6
21	26	120-28	Collar, Magna Grip
22	26	120-27	Pin, Magna Grip
25	4	117-44	T-Nut 1/4-20 Zn
26	30	120-24	Rivet, Alum - 3/32x3/8
27	76	120-09	Rivet 3/16 x 1 - Black
28	1	601-44	Nameplate, ARGO
28a	2	127-66	Nameplate, 6x6 Bigfoot
31	1	609-33RM	Firewall
32	1	125-84	Grommet, Rubber
34	1	603-02	Floor Pan, Front (specify colour)
35	1	603-03	Floor Pan, Rear 6x6 (specify colour)
36	51	120-04	Washer .19x.50x.08 Zn
37	1	126-60	Vinyl Strip 1/2"x1/4"x37.5'
38	4	120-05	Washer .19x.50x.04 Zn
39	4	100-16	Clip, Hitch Pin 1.625 Zn

Ref.	Qty.	Part #	Description
40	2	100-18	Plug, Drain 5/8" x 13/32"
41	1	601-03	Seat, Rear LH - 6x6
42	1	601-02	Seat, Rear RH - 6x6
43	2	603-15	Washer, Plastic
44	2	108-01	Washer, Fender 1/4BSx1.25OD
45	2	103-08	HHCS 1/4-20x1.0 Zn
47	4	103-61	HHCS 3/8-24x1.5 GR5 Zn
48	4	117-24	Locknut, Nylon 3/8-24 Zn
49	1	616-16	Hitch Assembly
50	1	127-97	Plate, Caution - Keyswitch
51	1	126-65	Shifting Plate
53	1	126-67	Floor Pan Plate
54	1	126-68	Operation Plate
55	1	126-69	Fuel Plate
56	1	127-76	Plate, Capacity - Land/Water
57	1		Vehicle ID Plate
58	1		U.S. Plate, Non U.S. Argos only
59	1	127-51	Plate, Capacity - 6x6
61	1	125-41	Dash Handle, incl. 62
62	2		Plug cap, avail. only with 61
63	3	117-10	Locknut, Nylon #10-24 Zn
64	1	126-88	Bumper, Rubber
65	3	103-25	PHMS 10-24x3/4 Zn
66	1	602-38	Clip, Hood
67a	2	613-75	Bezel, Headlamp
67b	2	613-76	Bracket, Headlight Backing
68			<b>See Section 9.0 Electrical System</b>
69	8	103-24BL	OHPS T/S #6 x 1.0 Black Zn
71	1	616-19	Tube, Hitch - Insert
72	1	104-13	Pin, Top Link
73	1	117-15	Nut, Fin. Hex 3/8-16 Zn
74	1	602-27	Support, Adjustable
75	1	103-89	C/Bolt 3/8-16x3/4 GR2 Zn
76	1	108-06	Lockwasher 3/8 Zn
80	2	127-01	Reflector, Red
81	4	103-48	T/S Pan HD Phil #10x5/8 A Zn
82	1	104-11	Pin, Lynch
83	8	108-59	Lockwasher #10 Int. Tooth Zn

# 7.0 Frame and Drive System

# Bigfoot Parts Manual

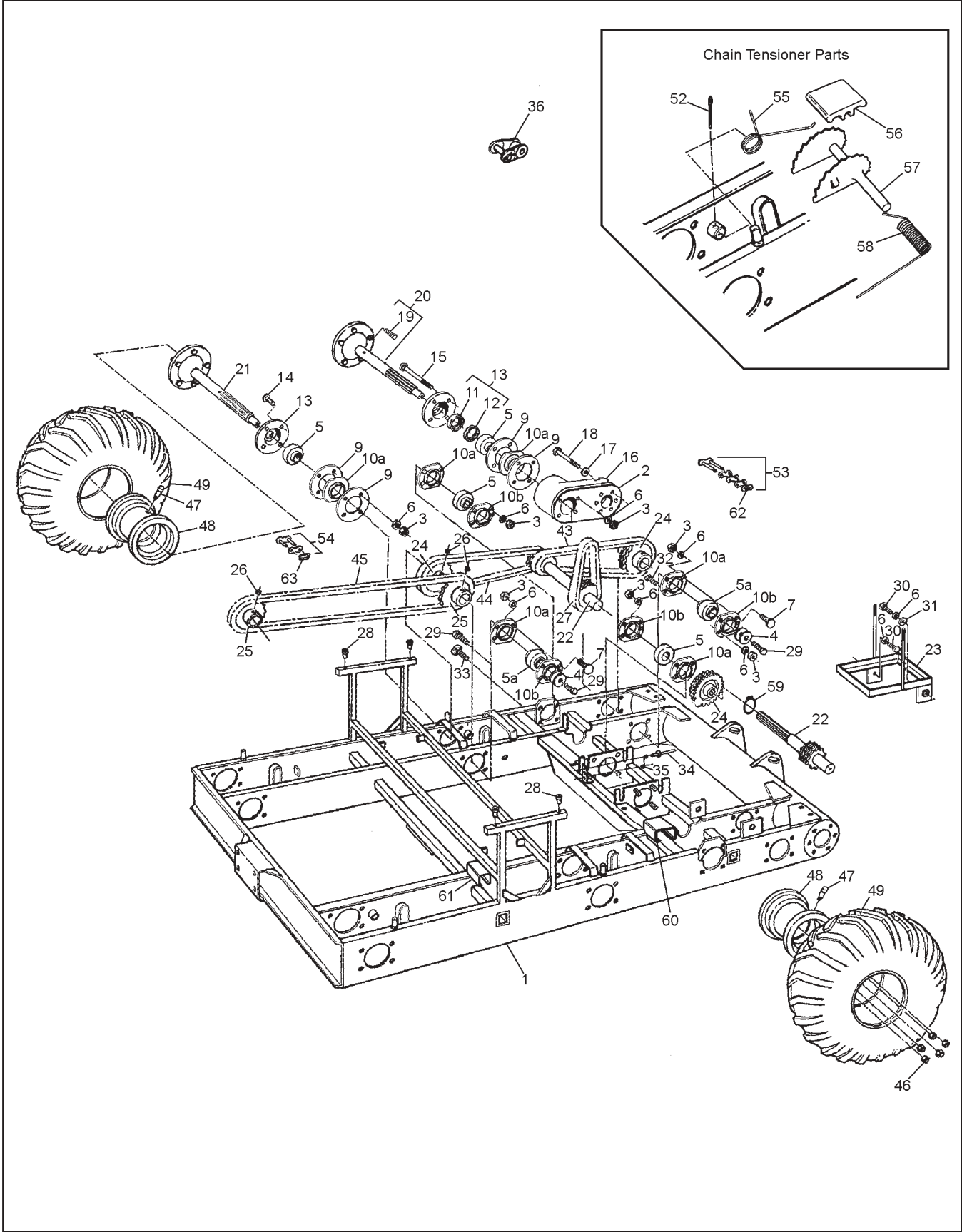

Ref.	Qty.	Part #	Description
1	1	606-60	Frame Asm - 6x6 Bigfoot
2	2	606-24	Gasket, Bearing Extension
3	64	117-15	Nut, Fin Hex 3/8-16 Zn
4	12	108-46	Washer .40x1.37x.12 Hi-Carbon
5	10	101-35	Bearing, Ball - 1.25
5a	6	101-41	Bearing, Ball - 1.0
6	66	108-06	Lockwasher 3/8 Zn
7	22	103-88	C/Bolt 3/8-16x1.0 GR5 Zn
9	12	605-89	Gasket, Outer Bearing Flange
10a	16	605-63	Flange - 4-hole
10b	10	101-20	Flange Greasable - 4 Hole
11	6	102-14	Seal, Oil 1.25x1.75x0.188
12	6	102-15	Seal, Oil 1.25x1.874x0.25
13	6	605-97	Flange Assem, Outer (incl. Refs. 11 & 12)
14	16	112-39	C/Bolt 3/8-16x1.75 GR5 Zn
15	8	112-134	C/Bolt 3/8-16 x 6.5 Zn
16	2	810-52	Bearing Extension (uses Refs. 17 & 18)
17	12	108-34	Washer 7/16 SAE Zn
18	12	103-81	HHCS 7/16-20x2.5 GR5 Zn
19	5x6	103-80	Stud, Wheel 7/16-20 x 1.125 #B271
20	2	810-73	Axle Assembly - Front (incl. Ref. 19)
21	4	810-75	Axle Assembly - Mid (incl. Ref. 19)
22	2	810-32	Shaft, Idler - 11T
23	1	604-84	Frame Assembly, Battery
24	6	810-28	Sprocket, Double - 24T
25	4	606-34	Sprocket - S60x19T
26	6	112-03	SHSS 5/16-18x3/8 1/2 DOG, PL
27	2	803-17	Chain, Idler RC50-2 x 40P (incl. Ref 53)
28	4	117-64	Insert, 1/4-20
29	10	112-31	HHCS 3/8-16 x 1.0 2B GR8 Zn
30	2	112-14	HHCS 3/8-16x.75 GR5 Zn
31	1	108-15	Washer 3/8 SAE Zn
32	2	103-82	HHCS 3/8-16x1.5 GR5 Zn
33	4	112-61	C/Bolt 3/8-16x1.25 GR5 Zn
34	2	120-15	Rivet 1/8 x 7/16
35	1	126-11	Spring
36		127-80	Link, Half - RC60 - 1 (opt.)
43	2	603-17	Chain RC50 - 2x42P - Front (incl. Ref 53)
44	2	603-26	Chain RC50 - 2x76P - Mid (incl. Ref 53)
45	2	603-83	Chain RC60 - 1x88P - Rear (incl. Ref 54)
46	5x6	117-35	Nut, Wheel 7/16-20 Zn
47	6	125-26	Valve, Tire
48	6	127-61C	Rim - 10x9 - Charcoal
49	6	127-60	Tire, Goodyear Rawhide III 25x12-9
52	4	100-01	Pin, Cotter 1/8 x 1.50 Zn
53	1x6	100-96	Con. Link, RC50-2 H.D.
54	1x2	603-84	Con. Link, RC60-1 H.D.
55	4	127-65	Spring Torsion - 1.16x0.35
56	4	606-39	Slider Block - 1/2" Shaft
57	4	606-35	Tensioner Asm, Chain
58	4	127-64	Spring, Torsion - .76 x 1.9
59	2	107-10	Retaining Ring
60	2	606-41	Slide, Chain - 2"
61	2	606-42	Slide, Chain - 1.25"
62	6	603-95	Spring Clip - RC 50 Closed
63	4	603-96	Spring Clip - RC 60 Closed

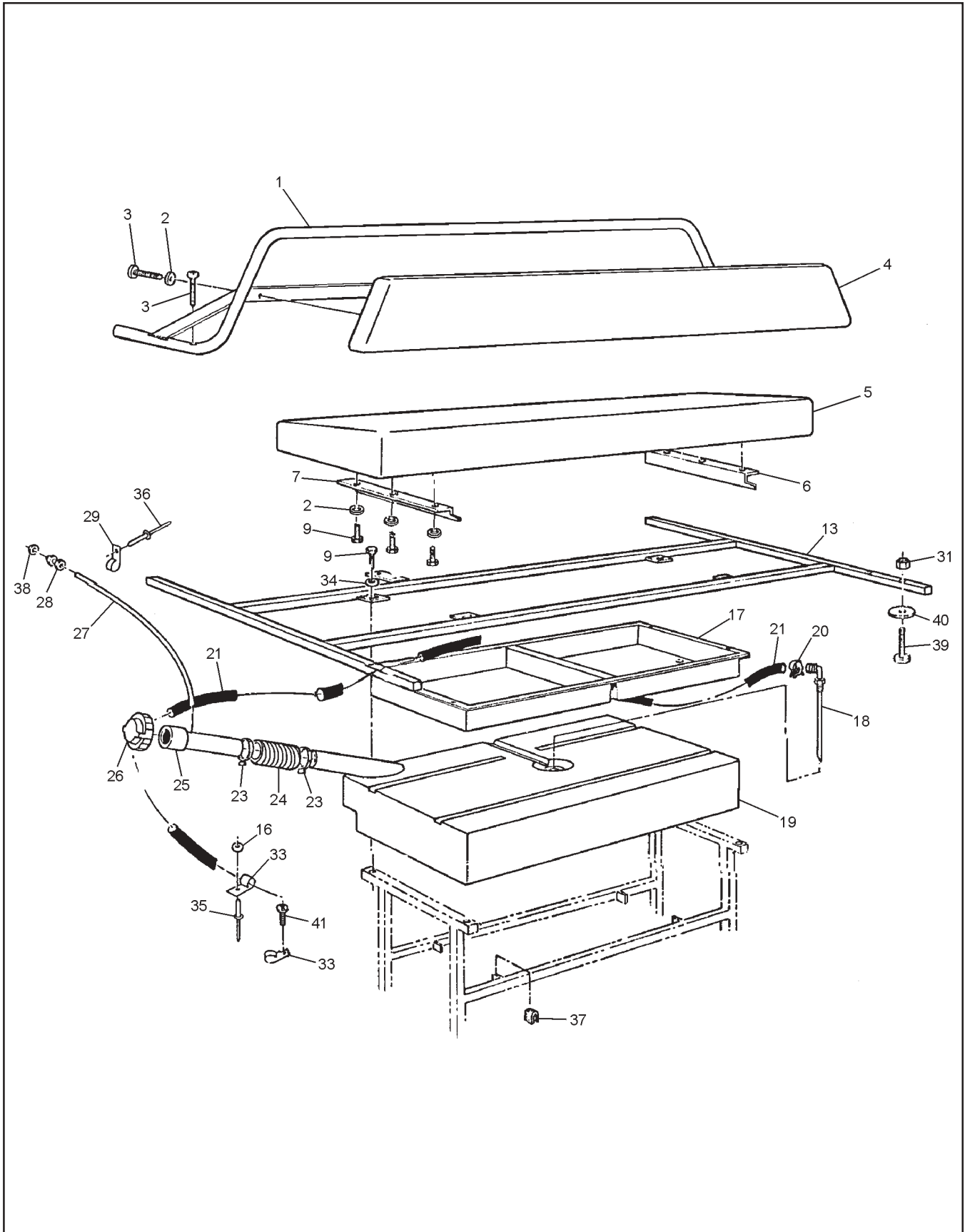



Ref.	Qty.	Part #	Description
1	1	803-50	Handrail Assembly
2	10	108-03	Lockwasher 1/4 Zn
3	6	112-41	PHMS, PHIL 1/4-20x1.25 Zn
4	1	608-39	Back Pad Assembly
5	1	608-43	Seat, Bench
6	1	608-30	Angle, Left
7	1	608-31	Angle, Right
9	10	112-04	HHCS 1/4-20x3/4 Gr2 Zn
13	1	804-17	Frame Assembly, Seat
16	3	120-04	Washer .19x.50x.08 Zn
17	1	608-32	Tool Box
18	1	608-28	Pickup Assembly, Fuel (see Ref. 19)
19	1	608-24	Tank, Fuel 32 litre (incl. Ref. 18)
20	2	112-79	Clamp, Hose, 1/2" - Black
21	1	608-42	Fuel Hose - 110"
23	2	100-12	Clamp, Gear 2.25" HF-36
24	1	125-94	Hose, Filler
25	1	126-47	Fuel Neck Assembly
26	1	126-46	Cap, Fuel
27	1	126-77	Hose, Vent 93" 6x6
28	1	126-50	Male Connector, 1/4"
29	5	126-94	Clamp, Nylon Wire - 1/4" ID
31	12	117-10	Locknut, Nylon #10-24 Zn
33	4	126-93	Clamp, Nylon Wire - 1/2" ID
34	4	108-08	Washer, .28 x .62 x .04 Zn
35	3	120-09	Rivet 3/16x1 - Black
36	6	120-13	Rivet, 3/16 x 5/8 - Black
37	4	702-06	Foam Cushion
38	1	117-54	Locking PAL Nut, 1/2-20
39	12	112-07	RHMS 10-24 x 1.50 Zn
40	12	108-42	Washer .21x1.0x.06 Zn
41	1	103-48	T/S Pan HD Phil #10x5/8 A Zn

# 9.0 Electrical System

# Bigfoot Parts Manual

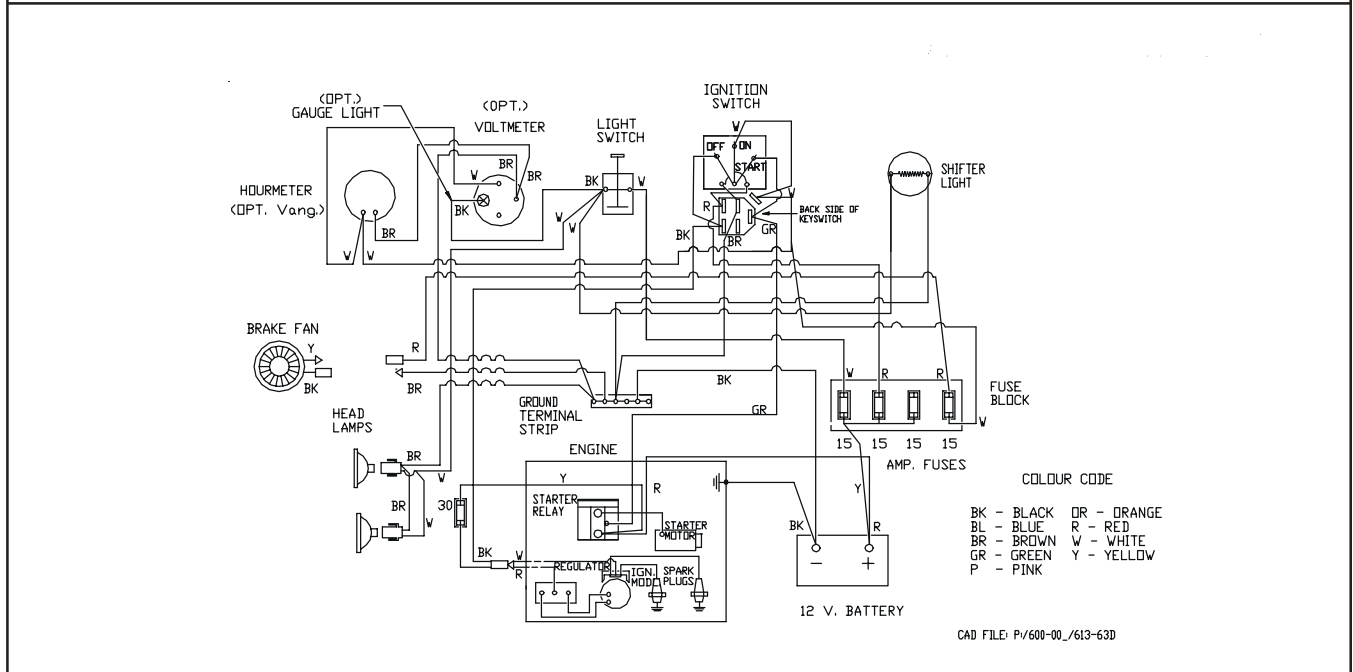
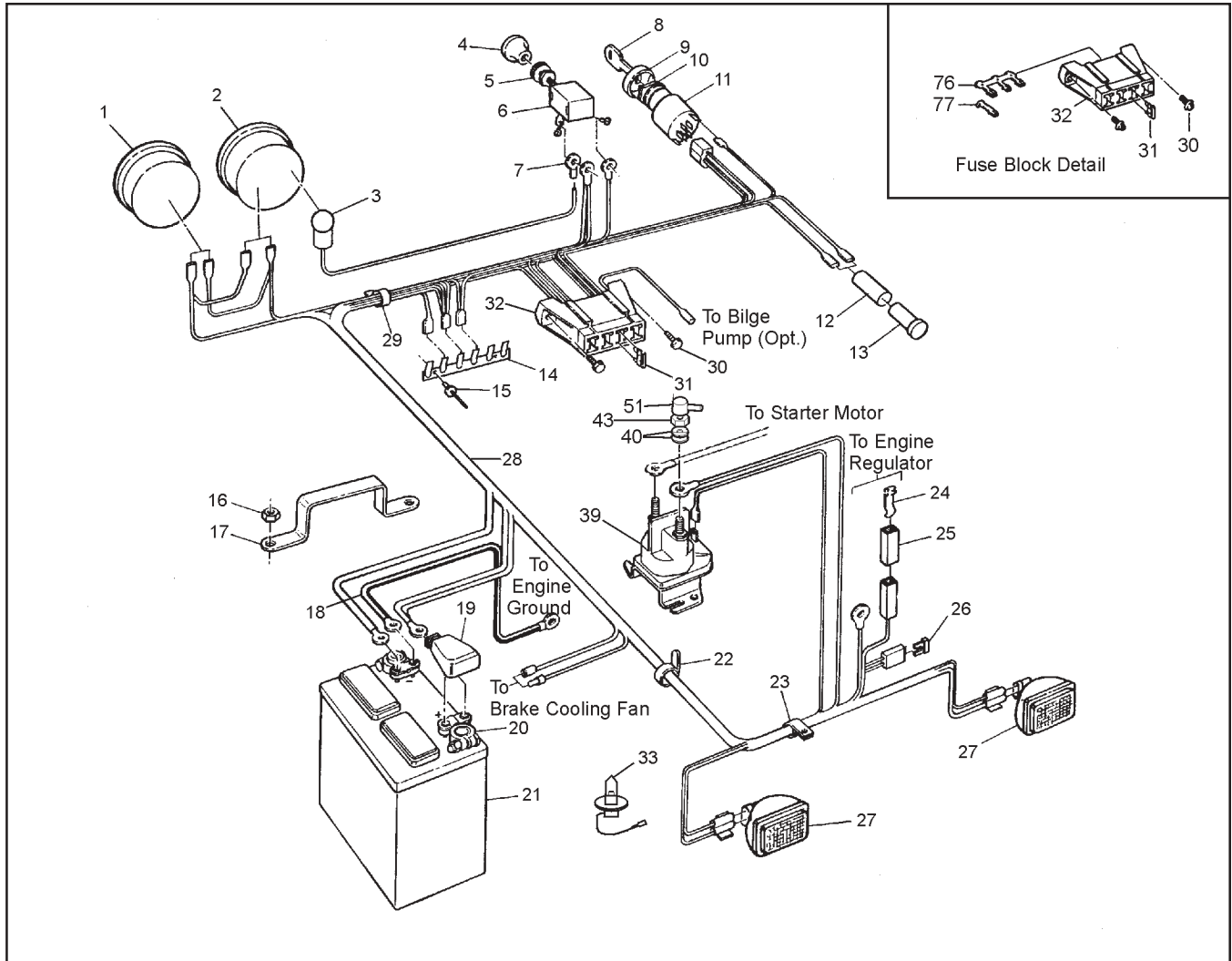

Ref.	Qty.	Part #	Description
1	1	632-15	Hourmeter #56458-10 (#876EM)
2	1	633-10	Voltmeter #07583-15 (#830EM)
3	2	634-10	Light Kit, #06215-00 5/8" dia, see Ref. 32 & 33 (opt.)
4	1	126-76	Knob, Light
5	1	108-55	Lockwasher 7/16 Ext. Tooth
6	1	100-62	Switch, Light
7	1	118-30	Terminal, Eye - #10
8	2	127-108	Key,molded
9	1	127-107	Cover, nut
10	1	127-106	Nut, flanged - plastic
11	1	127-105	Switch - Egnition
12	1	118-48	Heat Shrink
13	1	634-08	Light, Indicator
14	1	613-37	Terminal Strip, Ground
15	2	120-15	Rivet 1/8 x 7/16
16	2	117-21	Locknut, Nylon 5/16-18 Zinc
17	1	604-52	Bracket, Battery Retaining
18	1	613-14	Ground Wire
19	1	127-55	Cap, Battery Terminal - Red
20	2	127-56	Terminal, Battery Post
21	1	127-54	Battery
22	8	100-64	Tie Wrap - 5.5" - Black
23	10	126-93	Clamp, Nylon Wire - 1/2" ID
24	1	118-56	Contact
25	1	118-57	Connector Housing
26	1	118-51	Fuse, 30A 2-prong (AT030)
27	2	613-69	Headlamp, Halogen (incl. Ref. 33)
28	1	613-63	Wire Harness
29	1	127-24	Clamp, Nylon - 1" ID
30	2	112-51	Screw, IHWH T/C #10-24x5/8
31	4	118-49	Fuse, 15 A 2-prong (AT015)
32	1	118-60	Block Fuse - 8 position (4 fuse)
33	2	127-46	Bulb, Headlight - Halogen
39	1	613-68	Starter Relay
40	5	108-03	Lockwasher 1/4 Zinc
43	2	117-20	Nut, Fin. Hex 1/4-20 Zinc
51	1	613-45	Insulator, Terminal (6 ga.)
76	1	118-63	Terminal, Fuse - Triple
77	5	118-62	Terminal, Fuse - Single

# **ARGO** Products Manufactured by:

## **Ontario Drive & Gear Limited**

220 Bergey Court  
New Hamburg, Ontario  
Canada N3A 2J5  
Phone: (519) 662-2840  
Fax: (519) 662-2421

**ODG** *Dedicated to quality and performance*