

Argo 6x6
BIGFOOT



ARGO

BIGFOOT

PARTS MANUAL

Model Nos. V698-58
From Serial # BF13028

Foreword

ODG has prepared this parts manual for the BIGFOOT model to assist both qualified mechanics and vehicle owners in ordering correct, quality replacement ARGO parts.

Proper and regular service, and replacing old, worn or broken parts with the correct ARGO replacement parts, are both essential to prolonging the life of the ARGO. Please refer to this parts manual before ordering any replacement part.

All information contained in this BIGFOOT Parts Manual is based on the latest product specification available at time of printing. If your BIGFOOT differs from the specifications contained in this manual, contact Ontario Drive & Gear Limited for information.

ODG reserves the right to alter specifications on the BIGFOOT model at any time, without obligation or prior notification.

Reproduction of the BIGFOOT Parts Manual No. 698-58-5, in whole or in part, is prohibited without prior written permission from Ontario Drive & Gear Limited.

Model Identification

BIGFOOT - Model No. V698-58

Explanation of Parts Manual Format

Ref - Reference number between assembly diagram and component parts list

Part No. - Argo replacement part number for identification and re-ordering

Description - Part description for identification and re-ordering

Qty - Indicates the quantity of a part used in an Assembly

ARGO 6x6 BIGFOOT



Using the Parts Manual

1. Find the major vehicle assembly in the Table of Contents on this page, and turn to that section.
2. Locate the part in the illustration that you wish to order.
3. Refer to the parts list in that section.
4. Find the correct part number (Part No.), part description (Description) and correct quantity (Qty).
5. Use *only* this information to order ARGO replacement parts. *DO NOT* attempt to order a replacement part by reference number or page number.

Table of Contents

Foreword	i
Model Identification	i
Using the Parts Manual	ii
1.0 Transmission	1
2.0 Intake and Exhaust System	3
3.0 Clutch System	4
4.0 Power Pack Assembly	5
5.0 Brake System - Hydraulic	7
6.0 Vehicle Body & Firewall	9
7.0 Frame & Drive System	11
8.0 Fuel System & Seat Assembly	13
9.0 Electrical System	15

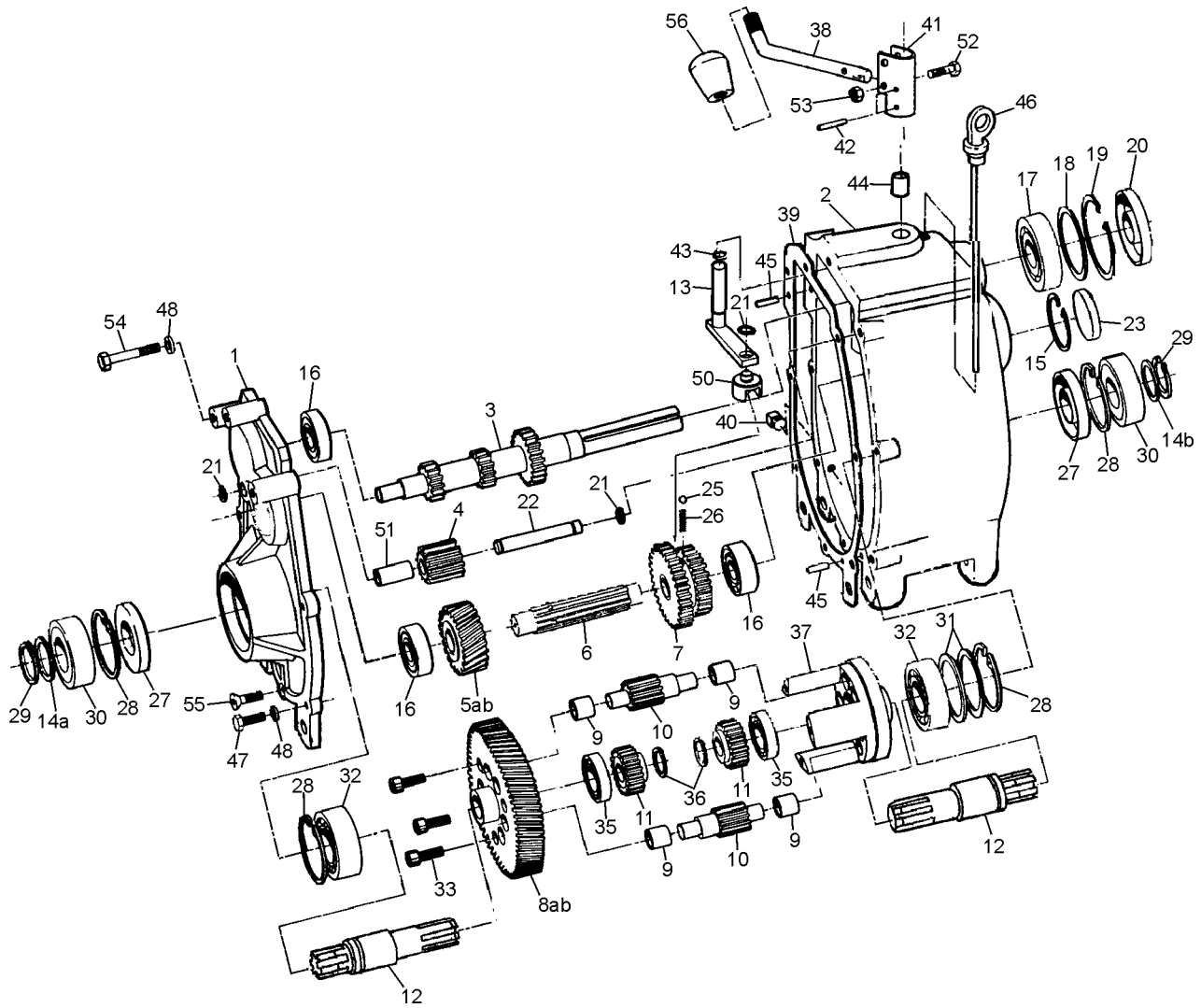

Ref.	Qty.	Part #	Description
.	1	610-18H	Transmission Asm - H, does not include Refs 38, 52, 53 & 56
1	1	34-68	Cover, Transmission
2	1	34-99	Housing, Transmission
3	1	34-21	Shaft, Input - 13/21T
4	1	34-16A	Gear, Idler 13T (incl. Ref. 51)
5a	1	34-96	Gear, Helical - 26T-H
5b	1	34-95	Gear, Helical - 24T-M
6	1	34-94	Shaft, Spline
7	1	34-91	Gear, Double - 26/33T
8a	1	34-43	Gear Plate - 71T-H
8b	1	34-22	Gear Plate - 73T-M
9	12	105-03	Bushing, Oilite 1/2 x 3/4
10	6	34-13	Gear, Planet - 12T
11	2	34-14	Gear, Sun - 21T
12	2	34-98	Shaft, Output
13	1	34-65	Shifter Asm
14a	1	114-04	Washer, Shim .040 Thk
14b	1	114-05	Washer, Shim .020 Thk
15	1	106-01	Retaining Ring
16	3	101-01	Bearing, Ball 6204Z-C3
17	1	101-16	Bearing, Ball 6206-C3
18	as req.	114-02	Washer, Shim 2.06x2.42x.02
19	1	106-05	Retaining Ring
20	1	102-05	Seal, Oil WBS 30x62x10
21	3	107-05	Retaining Ring
22	1	34-11	Pin, Dowel 1/2 x 3.50
23	1	31-07	Plug Plate
25	1	109-05	Ball, Steel 6mm 62-67 Rc
26	1	34-32	Spring, Compression - 7/32 x 0.50
27	2	102-03	Seal, Oil WBS 30x72x10
28	4	106-03	Retaining Ring
29	2	107-02	Retaining Ring
30	2	101-05	Bearing, Ball 6306-2NSE C3
31	2	114-01	Washer, Shim 2.25x2.81x.02
32	2	101-03	Bearing, Ball 6207-C3
33	3	103-04	SHCS 5/16-18 x 1.0 Bare
35	2	101-15	Bearing, Ball 6005-C3
36	2	107-04	Retaining Ring
37	1	34-08	Cage
38	1	610-77	Lever, Shift
39	1	34-47	Gasket, Cover - 1/64"Thk
40	1	103-02	Plug, Magnetic 3/8 - 18 NPT Sq. Hd.
41	1	34-86	Holder, Shift Lever
42	2	111-01	Pin, Spring 5/32 x 1.00 - Slotted
43	1	113-01	O-Ring
44	1	105-02	Bushing, Oilite 1/2x 1.0
45	2	104-03	Pin, Dowel 1/4 x 7/8
46	1	34-77	Dipstick - with Breather
47	4	103-06	HHCS 5/16-18x1.0 GR5 Zinc
48	7	108-05	Lockwasher 5/16 Zinc
50	1	34-63	Shift Yoke
51	1	105-05	Bushing, Oilite 1/2 x 1.5 (in Ref 4)
52	1	103-97	HHCS 1/4-20x1.25 GR5 Zinc
53	1	117-27	Locknut, Nylon 1/4-20 Zinc
54			See Section 4.0 Power Pack Assembly
55	1	103-95	FHSC 5/16-18x1.0 GR8 Zinc
56	1	126-38	Knob, Shift

2.0 Intake and Exhaust System

Bigfoot Parts Manual

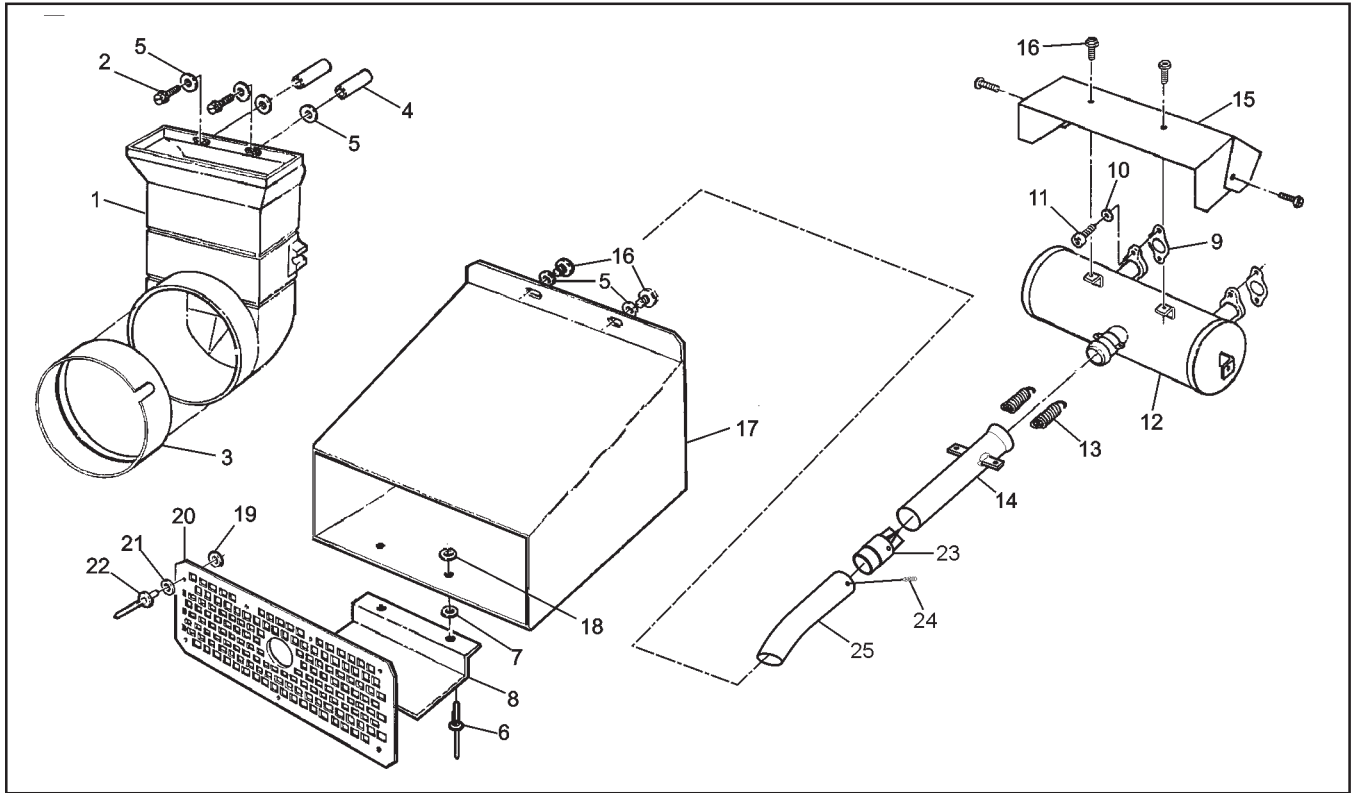

Ref.	Qty.	Part #	Description
1	1	603-81	Duct, Intake
2	2	112-48	Screw, T/S HH#14x2.25 Zinc
3	1	603-82	Seal
4	2	120-29	Spacer, .26 ID x 1.12 LG
5	6	108-08	Washer, .28 x .62 x .04 Zinc
6	2	120-13	Rivet 3/16 x 5/8 - Black
7	2	125-58	Washer, Fibre - W-77F
8	1	707-28	Support, Exhaust Duct
9	2	805024	Gasket
10	4	108-02	Lockwasher 5/16 Hi-Collar Bare
11	4	112-30	SHCS M8x1,25x20mm Zinc
12	1	807-90	Muffler, B&S V-Twin Weld Ass'y
13	2	126-57	Spring, Extension- 7/16x2.14
14	1	807-92	Pipe, Mufflertail - B&S
15	1	807-85	Shield, Muffler Heat
16	6	112-19	Screw, IHWH T/C Slot 1/4-20x1/2
17	1	707-32	Duct, Exhaust
18	2	120-04	Washer .19x.50x.08 Zinc
19	7	120-05	Washer .19x.50x.04 Zinc
20	1	707-31P	Screen, Exhaust
21	7	125-59	Washer, Fibre -.062x.25x.50
22	7	120-09	Rivet 3/16 x 1 - Black
23	1	807-67	Spark Arrester
24	1	112-43	Screw, IHWH #8x3/8
25	1	807-89	Tube, Tailpipe Outlet

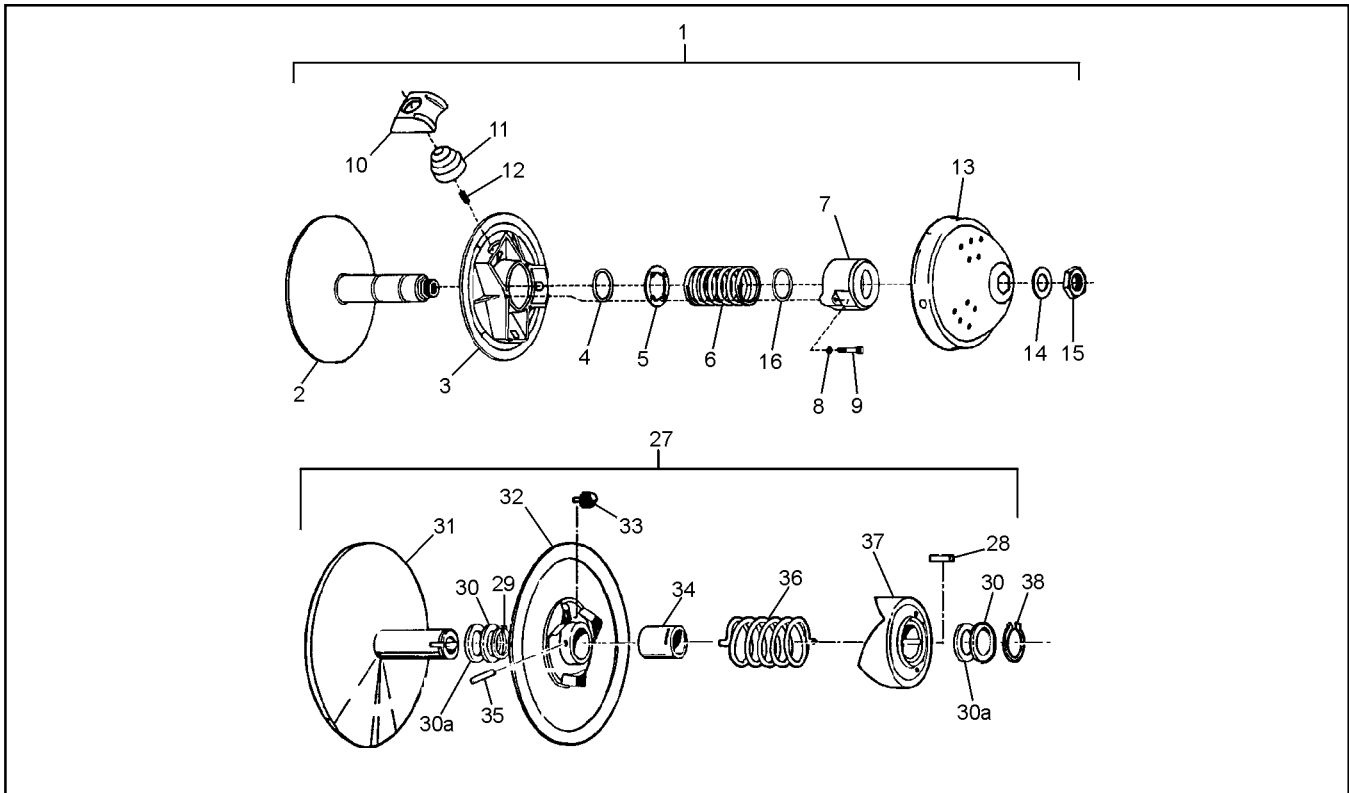

Ref.	Qty.	Part #	Description
1	1	127-73	Clutch, Driver (incl. Refs 2-15)
2	1	0405-0043	Pulley, Fixed half
3	1	0410-0007	Pulley, Sliding half
4	1	V08	Retaining Ring
5	1	V09	Plate, Spring Guide
6	1	V10-48-108-18	Spring
7	1	0440-0001	Cover, Spring
8	3	420-2453-700	Washer, Lock
9	3	222-9640-66	SHCS
10	3	0130-3002	Block, Red
11	3	C13-225	Weight, Lead 225g
12	3	C24-L1	Spring, Anti-noise
13	1	0115-0003(A)	Cap
14	1	0080-0153	Washer Zinc
15	1	0080-0100	Nut
16	1	V08C	Spring Ring
27	1	126-24	Clutch, Driven - Model "B" (incl. Refs 28-37)
28	1	ASK-5	Key 1/4 x 1/4 x 5/8
29	1	ASR-6	Retaining Ring
30	as req	ASA-1	Spacer .050" Thick
30a	as req	ASA-1-S	Spacer .025" Thick
31	1	AFK25.4-250OD01	Pulley, Half - Fixed
32	1	AMC-2-250OD01	Pulley, Half - Sliding incl. Refs. 33, 34 and 35
33	3	ANS-2-T	Shoe, Cam
34	1	AMB-2	Bushing, Bronze
35	1	111-01	Pin, Spring 5/32 x 1.00 - Slotted
36	1	ACS-3-188	Spring, Blue
37	1	AFC-4-C3D4	Cam
38	1	371-9031-000	Retaining Ring

4.0 Power Pack Assembly

Bigfoot Parts Manual

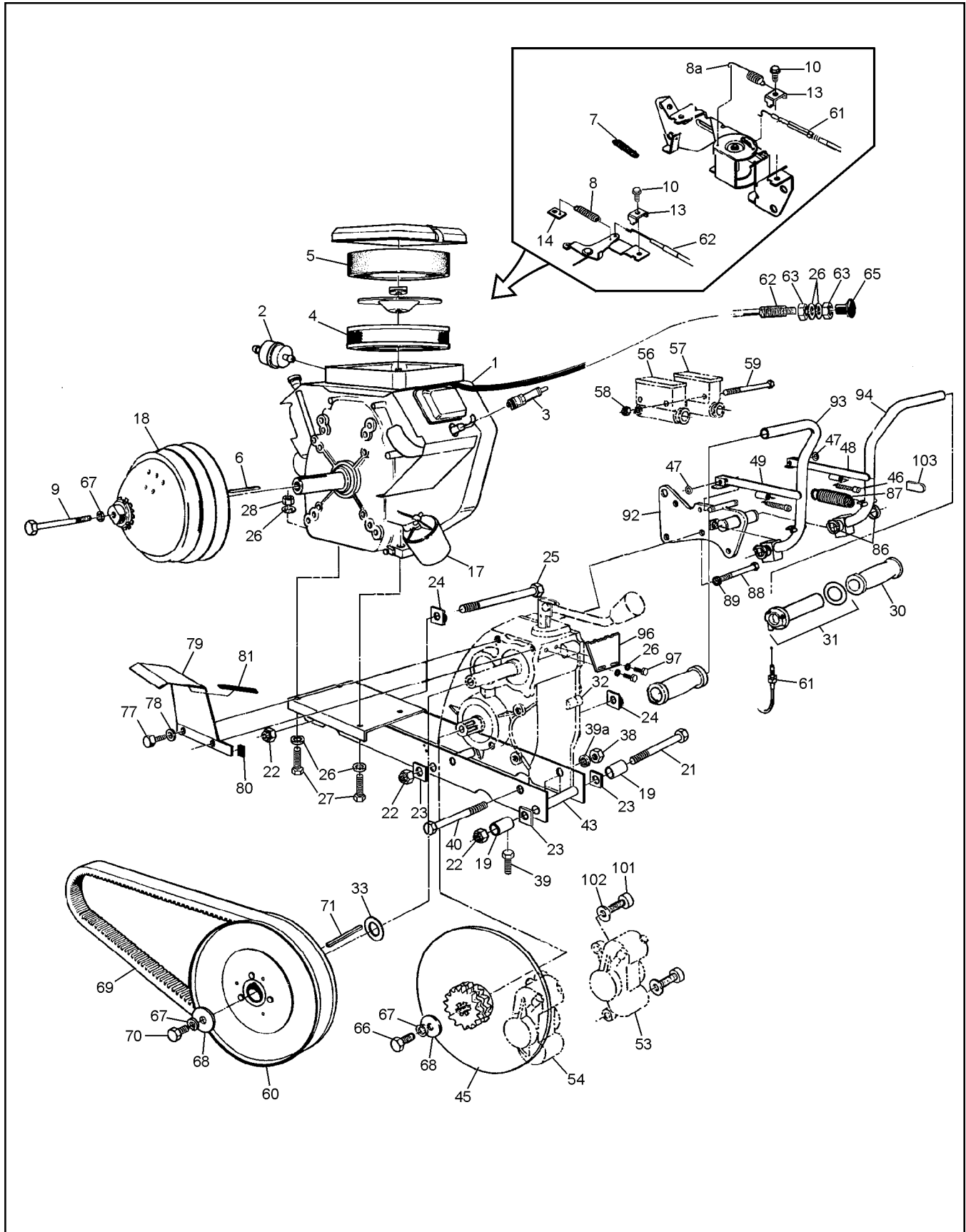

Bigfoot Parts Manual

4.0 Power Pack Assembly

Ref.	Qty.	Part #	Description	Ref.	Qty.	Part #	Description
1	1	127-53	Engine - Vanguard 18HP incl Refs 2,3,4,5,10,13,17 B&S #3504471282E1	48	1	810-21	Lever Asm, Brake - RH
2	1	125-64	Fuel Filter	49	1	810-20	Lever Asm, Brake - LH
3	2	126-74	Spark Plug #3926	53 to 57			See Section 5.0 Brake System
4	1	394018	Filter, Air	58	2	117-27	Locknut, Nylon 1/4-20 Zinc
5	1	272490	Element, Foam	59	2	103-66	HHCS 1/4-20x4.0 GR5 Zinc
6	1	110-03	Key 1/4x3/16x2.375 RC46	60			See Section 3.0 Clutch System
7	1	805458	Spring	61	1	612-101	Cable Asm, Throttle
8	1	125-88	Spring, Return	62	1	612-92	Cable Asm, Choke incl 63
8a	1	127-49	Spring, Return	63	2		Jam Nut, 5/16-24, Part of 62
9	1	112-28	HHCS 3/8-24x4.5 GR5 Zinc	65	1	126-75	Knob, Choke - Black
10	2	805169	Screw-Hex Head (Briggs #)	66	2	103-18	HHCS 3/8-24x1.25 GR5 Zinc
13	2	805170	Clamp - Casing (Briggs #)	67	4	108-06	Lockwasher 3/8 Zinc
14	1	601-86	Clip, Retainer	68	3	108-18	Washer .40x1.37x.12 Zinc
17	1	126-95	Filter, Oil	69	1	125-56	Drive Belt
18			See Section 3.0 Clutch	70	1	103-34	HHCS 3/8-16x1.25 GR5 Zinc
19	2	811-14	Spacer	71	1	110-09	Key 1/4 x 1/4 x 3.0
21	1	112-57	HHCS 5/8-11x10.0 GR5 Zinc	77	2	103-17	HHCS 3/8-16x1.0 GR5 Zinc
22	3	117-09	Locknut, Nylon 5/8-11 Zinc	78	2	108-26	Washer 3/8 Zinc
23	3	811-09	Washer, Square .64 ID	79	1	603-29	Guard, Belt Protect
24	2	811-15	Washer, Square Lock .64 ID	80	1	601-92	Trim, Vinyl - 1.5"
25	2	112-58	HHCS 5/8-11x7.5 GR5 Zinc	81	1	601-93	Trim, Vinyl - 4.25"
26	12	108-24	Washer 5/16 SAE Zinc	86	4	106-07	Retaining Ring
27	4	112-27	HHCS 5/16-18x1.75 Gr5 Zinc	87	2	127-33	Spring, Extension
28	4	117-21	Locknut, Nylon 5/16-18 Zinc	88	3	103-55	HHCS 5/16-18x2.75 Gr5 Zinc
30	2	127-35	Grip, Molded Rubber	89	3	108-05	Lockwasher 5/16 Zinc
31	1	127-81	Throttle Twist Grip	92	1	850-61	Bracket Asm, Steering
32			See Section 1.0 Transmission	93	1	812-27	Lever Asm, Steering - LH
33	as req	108-36	Washer 1.03x1.37x.06 Zinc	94	1	812-26	Lever Asm, Steering - RH
38	2	117-06	Nut, Fin Hex 1/2-13 Zinc	96	1	610-81	Shift Gate, Transmission
39	2	103-53	HHCS 3/8-16x3.0 Full Thread	97	2	112-01	HHCS 5/16-8x3/4 Gr5 Zn
39a	2	108-07	Lockwasher 1/2 Zinc	101	4	103-41	SHCS 3/8-16 x 1.25 Zinc
40	2	103-20	HHCS 1/2-13x6.5 GR5 Zinc	102	4	108-23	Washer 3/8 SAE Gr8 - Dich.
43	1	611-71	Frame, Power Pack	103	2	126-89	Cap, Vinyl - Black
45	2	610-80	Brake Disc - #50-2 x 13T				
46	2	103-69	SHCS 1/4-20 x 1.5 Zinc				
47	2	113-02	O-Ring				

5.0 Brake System - Hydraulic

Bigfoot Parts Manual

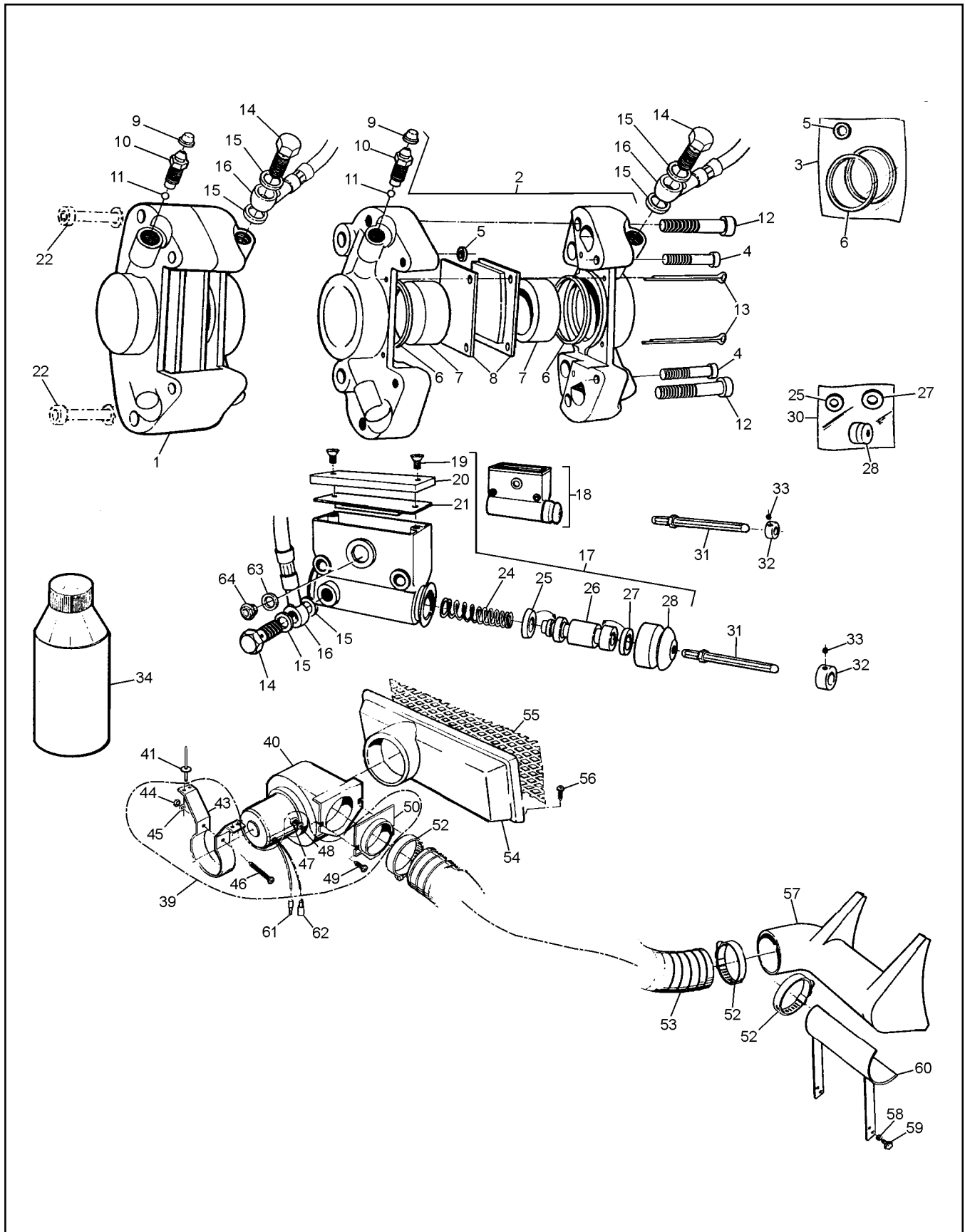

Ref.	Qty.	Part #	Description
1	1	166-01RM	Caliper, Brake-L w/o pads (incl. Refs 5,6,7,9-12)
2	1	166-02RM	Caliper, Brake-R w/o pads (incl. Refs 5,6,7,9-12)
3	2	161-01	O-Ring Kit, Caliper (incl. Refs 5 & 6)
4	2	160-40	SHCS M8 x 1,25 x 40 Zinc
5	1		Seal, Rubber-5mm (see Ref 3)
6	2		Seal, Piston-41mm (see Ref 3)
7	2x2	168-05	Piston 41mm
8	1	170-01	Brake Pad Set (4)- Non-asbestos
9	1x2	168-20	Plug, Rubber
10	1x2	168-03	Screw, Bleeding M10 x 1,0
11	1x2	109-03	Ball, Steel - 7/32 Dia.
12	2x2	160-41	SHCS M10x1,5x50mm Zinc
13	2x2	168-06	Pin, Cotter 3,2 x 50mm
14	4	160-44	Bolt, Banjo-M10x1,0x21,0 Zinc
15	8	160-01	Washer, Copper
16	1x2	163-01	Hose Asm, Hydraulic-300mm
17	1	165-06	Master Cylinder -left (incl. Refs 19 to 21, 24 to 28, 63 & 64)
18	1	165-05	Master Cylinder - right (incl. Refs 19 to 21, 24 to 28, 63 & 64)
19	2x2	160-42	FHMS M5 x 0,8 x 6mm
20	1x2	168-08	Cover
21	1x2	168-09	Cover, Rubber
22			See Section 4.0 Power Pack Assembly
24	1x2	162-02	Spring, comp. 0.59 x 1.5
25	1x2		Seal, Primary, 19mm (See Ref. 30)
26	1x2	168-10	Piston 19mm Dia.
27	1x2		Seal, Secondary, 19mm (See Ref. 30)
28	1x2		Boot, Rubber (See Ref. 30)
30	1x2	161-25	O-Ring Kit-Master Cylinder (incl. Refs 25, 27 & 28)
31	2	812-13	Pin Asm, Plunger-Adjustable
32	2	812-17	Collar
33	2	112-02	SHSS 10-24x1/4 Knurl Cup Pt,PL
34		126-19	Fluid, Brake-Silicon Dot 5
39	1	125-92	Adpt. & Mounting Kit - Fan (incl. Refs 43 to 50)
40	1	125-91	Blower Fan
41	4	120-13	Rivet 3/16x5/8 - Black
43	1		Mounting Bracket
44	1		Nut, #10-32
45	1	See	Lockwasher, 3/16"
46	1	Ref. 39	Screw, #10-32 x 2"
47	2	Above	Nut, 1/4-20
48	2		Lockwasher, 1/4"
49	2		Screw, 1/4-20 x 5/8"
50	1		Adaptor, 3" Dia.
52	3	125-35	Clamp, Gear 3.50" HF-52
53	1	127-44	Hose, Intake 3" dia. x 46"
54	1	601-89	Intake Flange (specify colour)
55	1	126-61	Intake Screen
56	4	112-56	Pan HD Phil T/S #10x3/4 A Zinc
57	1	127-39	Brake Cool Air Duct
58	4	108-03	Lockwasher 1/4 Zinc
59	4	112-19	Screw, IHWH T/C Slot 1/4-20x1/2
60	1	668-11	Bracket Asm, Duct Mounting
61	1	118-02	Terminal, Male
62	1	118-03	Terminal, Female
63	1x2	160-03	O-Ring, Oil Window
64	1x2	168-14	Oil Window, Master Cylinder

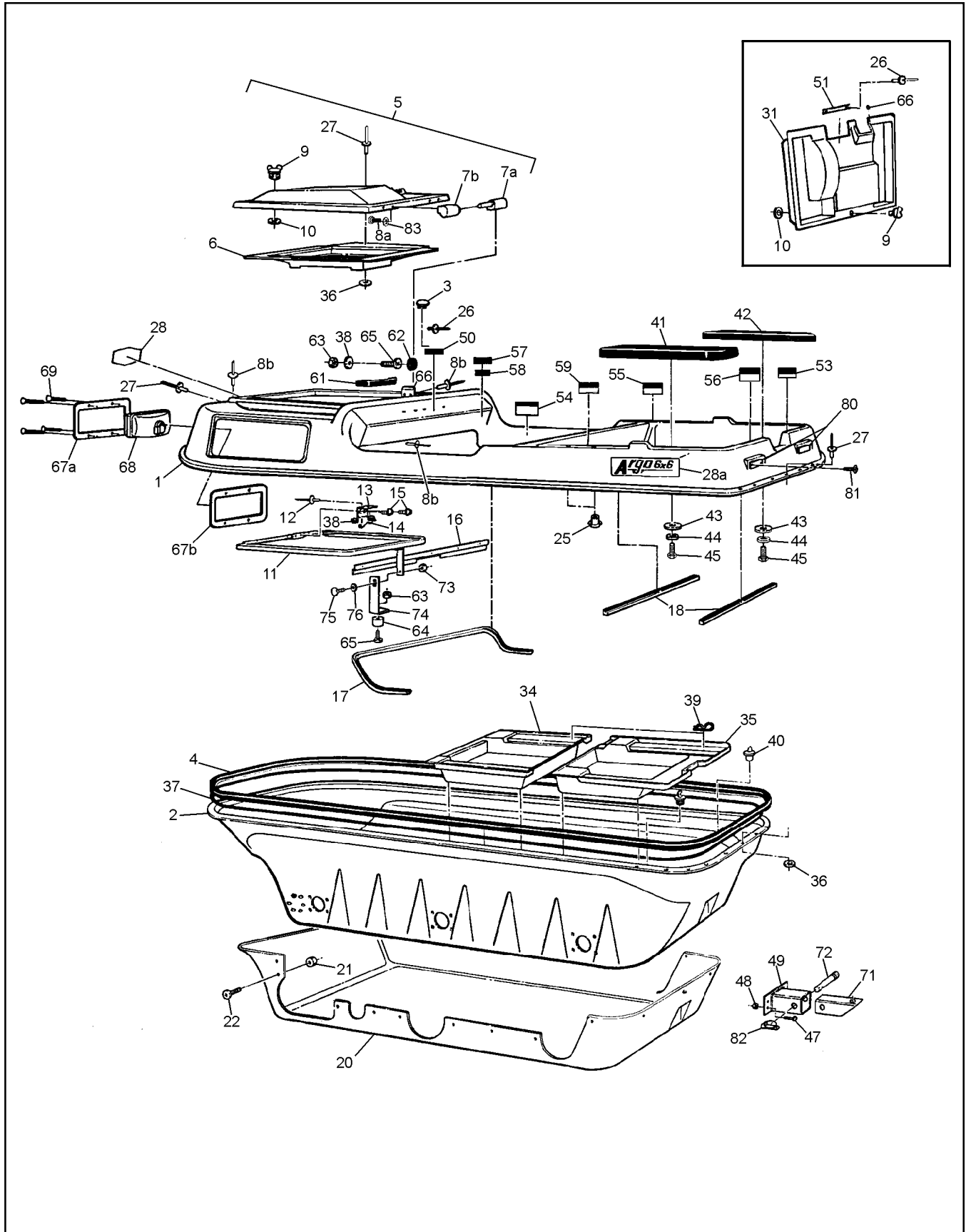

Bigfoot Parts Manual

6.0 Vehicle Body & Firewall

Ref.	Qty.	Part #	Description
1	1	601-32	Body & Hood, Upper - Bigfoot Replacement, specify colour (incl. Ref 5, 11, 12, 13, 14, 15 & 38)
2	1	603-92	Body, Lower - Ext'd 6x6, specify colour
3	1	127-28	Plug, Nylon - Black
4	1	601-05	Bumper, Vinyl - 6x6
5	1	602-37	Hood Kit (specify colour) (incl. Ref 6 to 10, 27, 36, 66 & 83)
6	1	801-47	Duct, Intake Transition (specify colour)
7a	2	127-45A	Pin, Hinge
7b	2	127-45B	Knuckle, Hinge
8a	8	103-47	HHCS 10-24x1/2 Zinc
8b	12	120-13	Rivet 3/16 x 5/8 - Black
9	2	126-10	Wing Stud
10	2	126-09	Grommet, Alum.
11	1	602-24	Hood Frame Assembly
12	2	120-15	Rivet 1/8 x 7/16
13	1	601-69	Spring Plate
14	1	126-11	Spring
15	2	112-19	Screw, IHWH T/C Slot 1/4-20x1/2
16	1	602-29	Brace, Dash
17	1	601-08	Vinyl Trim, 84"
18	2	601-09	Vinyl Trim, 28"
20	1	663-11	Skid Plate - Ext'd 6x6
21	26	120-28	Collar, Magna Grip
22	26	120-27	Pin, Magna Grip
25	4	117-44	T-Nut 1/4-20 Zinc
26	30	120-24	Rivet, Alum - 3/32x3/8
27	76	120-09	Rivet 3/16 x 1 - Black
28	1	601-44	Nameplate, ARGO
28a	2	127-66	Nameplate, 6x6 Bigfoot
31	1	609-33	Firewall (incl. 9,10,26,32,51)
32	1	125-84	Grommet, Rubber
34	1	803-02	Floor Pan, Front (specify colour)
35	1	603-03	Floor Pan, Rear 6x6 (specify colour)
36	51	120-04	Washer .19x.50x.08 Zinc
37	1	126-60	Vinyl Strip 1/2"x1/4"x37.5'
38	4	120-05	Washer .19x.50x.04 Zinc
39	4	100-16	Clip, Hitch Pin 1.625 Zinc

Ref.	Qty.	Part #	Description
40	2	100-18	Plug, Drain 5/8" x 13/32"
41	1	601-03	Seat, Rear LH - 6x6
42	1	601-02	Seat, Rear RH - 6x6
43	2	603-15	Washer, Plastic
44	2	108-01	Washer, Fender 1/4BSx1.25OD
45	2	103-08	HHCS 1/4-20x1.0 Zinc
47	4	103-61	HHCS 3/8-24x1.5 GR5 Zinc
48	4	117-24	Locknut, Nylon 3/8-24 Zinc
49	1	616-16	Hitch Assembly
50	1	127-97	Plate, Caution - Keyswitch
51	1	126-65	Shifting Plate
53	1	126-67	Floor Pan Plate
54	1	126-68	Operation Plate
55	1	126-69	Fuel Plate
56	1	127-76	Plate, Capacity - Land/Water
57	1		Vehicle ID Plate
58	1		U.S. Plate, Non U.S. Argos only
59	1	127-51	Plate, Capacity - 6x6
61	1	125-41	Dash Handle, incl. 62
62	2		Plug cap, avail. only with 61
63	3	117-10	Locknut, Nylon #10-24 Zinc
64	1	126-88	Bumper, Rubber
65	3	103-25	PHMS 10-24x3/4 Zinc
66	1	602-38	Clip, Hood
67a	2	613-75	Bezel, Headlamp
67b	2	613-76	Bracket, Headlight Backing
68			See Section 9.0 Electrical System
69	8	103-24BL	OHPS T/S #6 x 1.0 Black Zinc
71	1	616-19	Tube, Hitch - Insert
72	1	104-13	Pin, Top Link
73	1	117-15	Nut, Fin. Hex 3/8-16 Zinc
74	1	602-27	Support, Adjustable
75	1	103-89	C/Bolt 3/8-16x3/4 GR2 Zinc
76	1	108-06	Lockwasher 3/8 Zinc
80	2	127-01	Reflector, Red
81	4	103-48	T/S Pan HD Phil #10x5/8 A Zinc
82	1	104-11	Pin, Lynch
83	8	108-59	Lockwasher #10 Int. Tooth Zinc

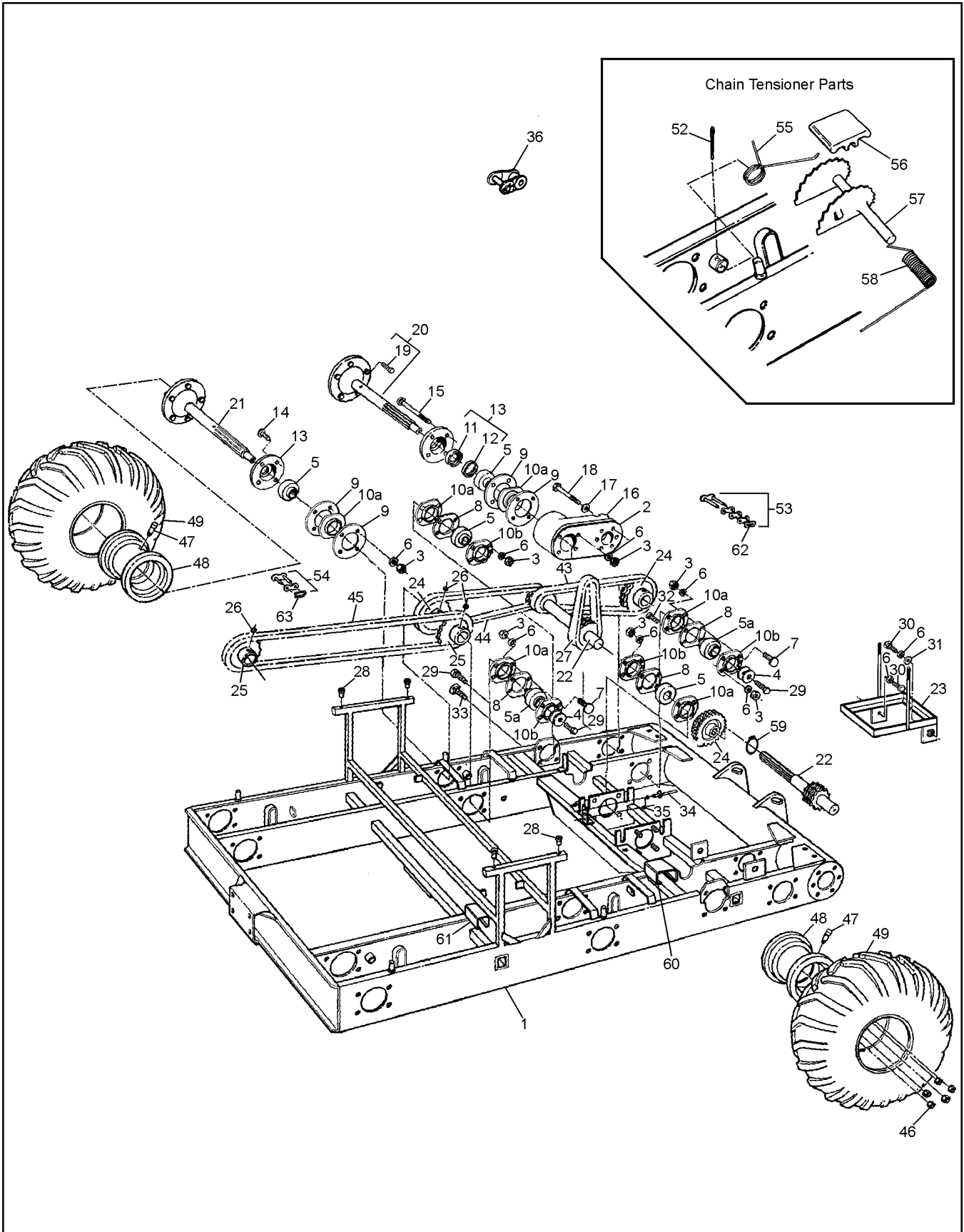

Ref.	Qty.	Part #	Description
1	1	606-60	Frame Asm - 6x6 Bigfoot
2	2	606-24	Gasket, Bearing Extension
3	64	117-15	Nut, Fin Hex 3/8-16 Zinc
4	12	108-46	Washer .40x1.37x.12 Hi-Carbon
5	10	101-35	Bearing, Ball - 1.25
5a	6	101-41	Bearing, Ball - 1.0
6	66	108-06	Lockwasher 3/8 Zinc
7	22	103-88	C/Bolt 3/8-16x1.0 GR5 Zinc
8	10	605-99	Gasket, Flange - Inner
9	12	605-89	Gasket, Outer Bearing Flange
10a	16	605-63	Flange - 4-hole
10b	10	101-20	Flange Greasable - 4 Hole
11	6	102-14	Seal, Oil 1.25x1.75x0.188
12	6	102-15	Seal, Oil 1.25x1.874x0.25
13	6	605-97	Flange Assem, Outer (incl. Refs. 11 & 12)
14	16	112-39	C/Bolt 3/8-16x1.75 GR5 Zinc
15	8	103-67	C/Bolt 3/8-16x6.0 GR2 Zinc
16	2	810-52	Bearing Extension (uses Refs. 17 & 18)
17	12	108-34	Washer 7/16 SAE Zinc
18	12	103-81	HHCS 7/16-20x2.5 GR5 Zinc
19	5x6	103-80	Stud, Wheel 7/16-20 x 1.125 #B271
20	2	810-73	Axle Assembly - Front (incl. Ref. 19)
21	4	810-75	Axle Assembly - Mid (incl. Ref. 19)
22	2	810-32	Shaft, Idler - 11T
23	1	604-84	Frame Assembly, Battery
24	6	810-28	Sprocket, Double - 24T
25	4	606-34	Sprocket - S60x19T
26	6	112-03	SHSS 5/16-18x3/8 1/2 DOG, PL
27	2	803-17	Chain, Idler RC50-2 x 40P (incl. Ref 53)
28	4	117-64	Insert, 1/4-20
29	10	112-31	HHCS 3/8-16 x 1.0 2B GR8 Zinc
30	2	112-14	HHCS 3/8-16x.75 GR5 Zinc
31	1	108-15	Washer 3/8 SAE Zinc
32	2	103-82	HHCS 3/8-16x1.5 GR5 Zinc
33	4	112-61	C/Bolt 3/8-16x1.25 GR5 Zinc
34	2	120-15	Rivet 1/8 x 7/16
35	1	126-11	Spring
36		127-80	Link, Half - RC60 - 1 (opt.)
43	2	603-17	Chain RC50 - 2x42P - Front (incl. Ref 53)
44	2	603-26	Chain RC50 - 2x76P - Mid (incl. Ref 53)
45	2	603-83	Chain RC60 - 1x88P - Rear (incl. Ref 54)
46	5x6	117-35	Nut, Wheel 7/16-20 Zinc
47	6	125-26	Valve, Tire
48	6	127-61C	Rim - 10x9 - Charcoal
49	6	127-60	Tire, Goodyear Rawhide III 25x12-9
52	4	100-01	Pin, Cotter 1/8 x 1.50 Zinc
53	1x6	100-96	Con. Link, RC50-2 H.D.
54	1x2	603-84	Con. Link, RC60-1 H.D.
55	4	127-65	Spring Torsion - 1.16x0.35
56	4	606-39	Slider Block - 1/2" Shaft
57	4	606-35	Tensioner Asm, Chain
58	4	127-64	Spring, Torsion - .76 x 1.9
59	2	107-10	Retaining Ring
60	2	606-41	Slide, Chain - 2"
61	2	606-42	Slide, Chain - 1.25"
62	6	603-95	Spring Clip - RC 50 Closed
63	4	603-96	Spring Clip - RC 60 Closed

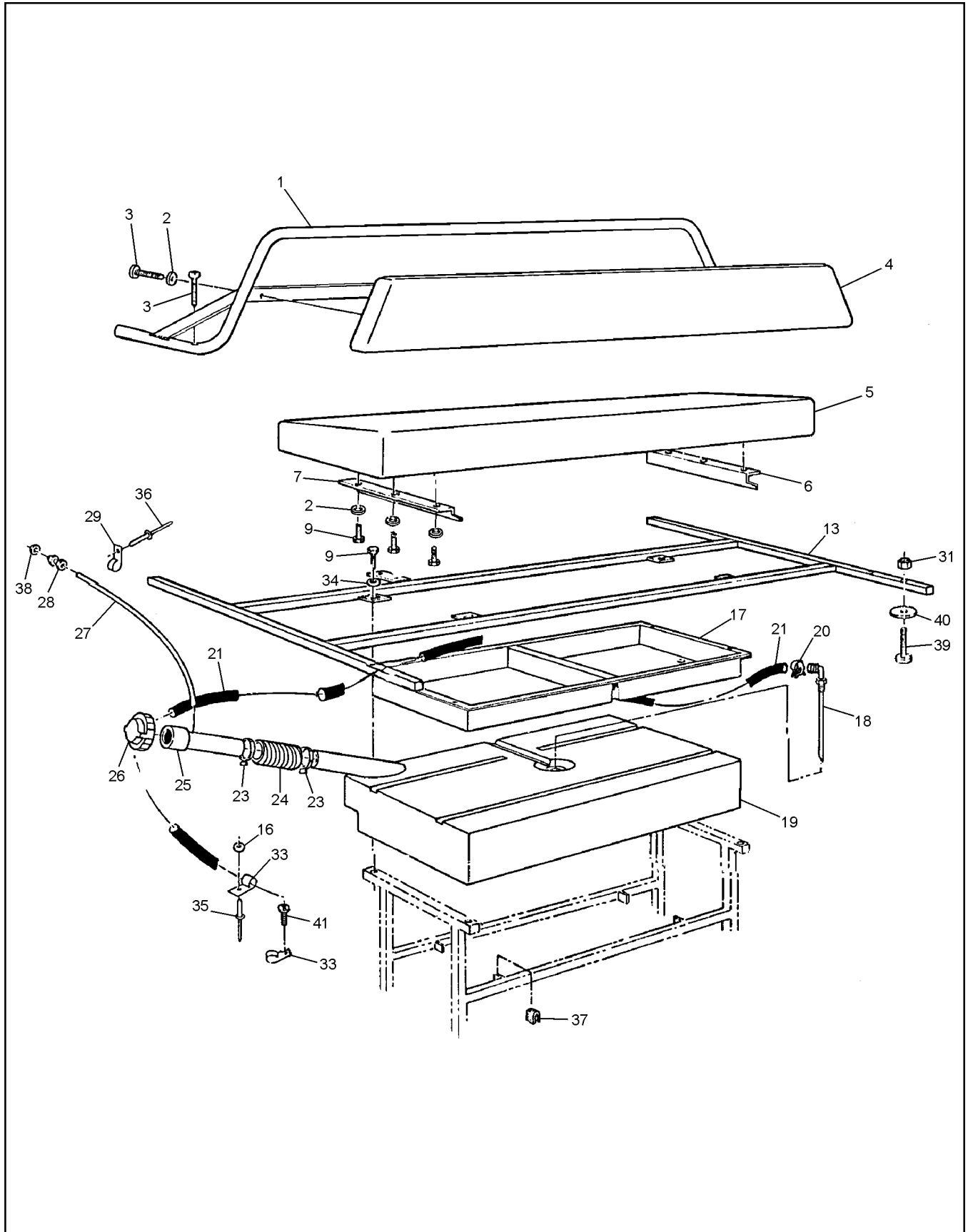

Bigfoot Parts Manual 8.0 Fuel System & Seat Assembly

Ref.	Qty.	Part #	Description
1	1	803-50	Handrail Assembly
2	10	108-03	Lockwasher 1/4 Zinc
3	6	112-41	PHMS, PHIL 1/4-20x1.25 Zinc
4	1	608-39	Back Pad Assembly
5	1	608-43	Seat, Bench
6	1	608-30	Angle, Left
7	1	608-31	Angle, Right
9	10	112-04	HHCS 1/4-20x3/4 Gr2 Zinc
13	1	804-17	Frame Assembly, Seat
16	3	120-04	Washer .19x.50x.08 Zinc
17	1	608-32	Tool Box
18	1	608-28	Pickup Assembly, Fuel (see Ref. 19)
19	1	608-24	Tank, Fuel 32 litre (incl. Ref. 18)
20	2	112-79	Clamp, Hose, 1/2" - Black
21	1	608-42	Fuel Hose - 110"
23	2	100-12	Clamp, Gear 2.25" HF-36
24	1	125-94	Hose, Filler
25	1	126-47	Fuel Neck Assembly
26	1	126-46	Cap, Fuel
27	1	126-77	Hose, Vent 93" 6x6
28	1	126-50	Male Connector, 1/4"
29	4	126-94	Clamp, Nylon Wire - 1/4" ID
31	12	117-10	Locknut, Nylon #10-24 Zinc
33	4	126-93	Clamp, Nylon Wire - 1/2" ID
34	4	108-08	Washer, .28 x .62 x .04 Zinc
35	3	120-09	Rivet 3/16x1 - Black
36	6	120-13	Rivet, 3/16 x 5/8 - Black
37	4	702-06	Foam Cushion
38	1	117-54	Locking PAL Nut, 1/2-20
39	12	112-07	RHMS 10-24 x 1.25 Zinc
40	12	108-42	Washer .21x1.0x.06 Zinc
41	1	103-48	T/S Pan HD Phil #10x5/8 A Zinc

9.0 Electrical System

Bigfoot Parts Manual

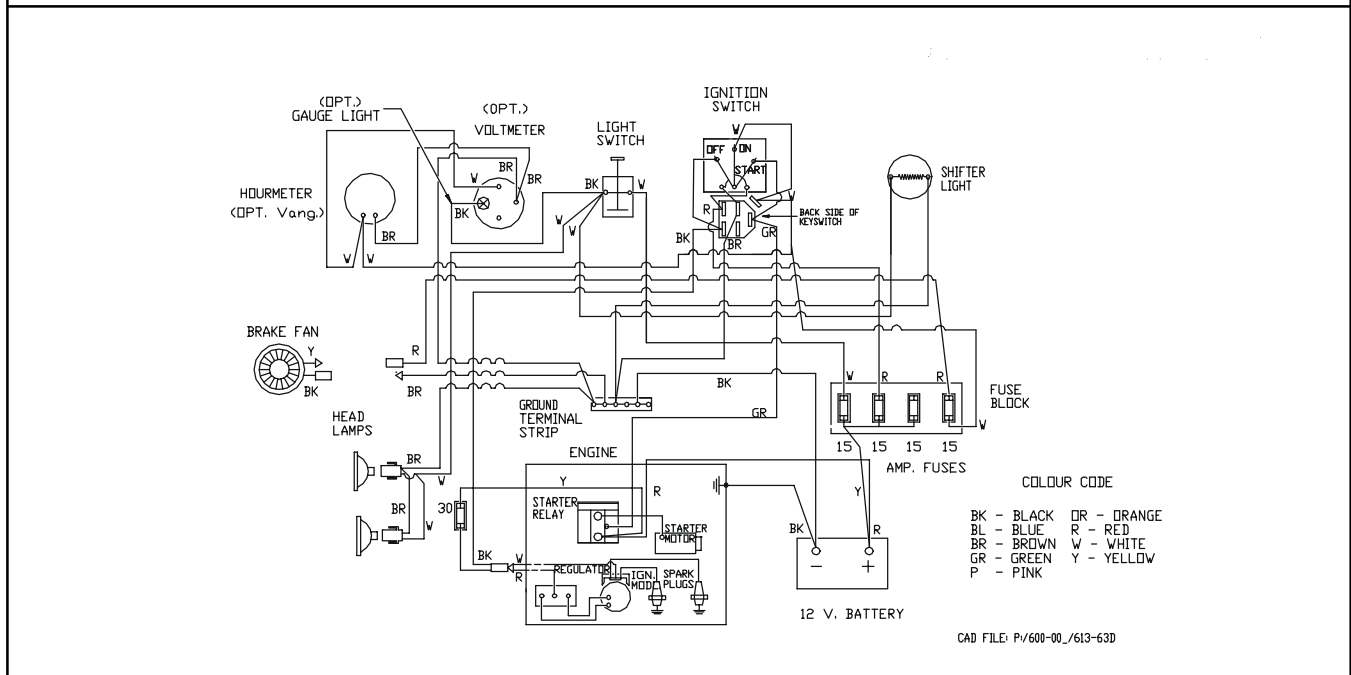
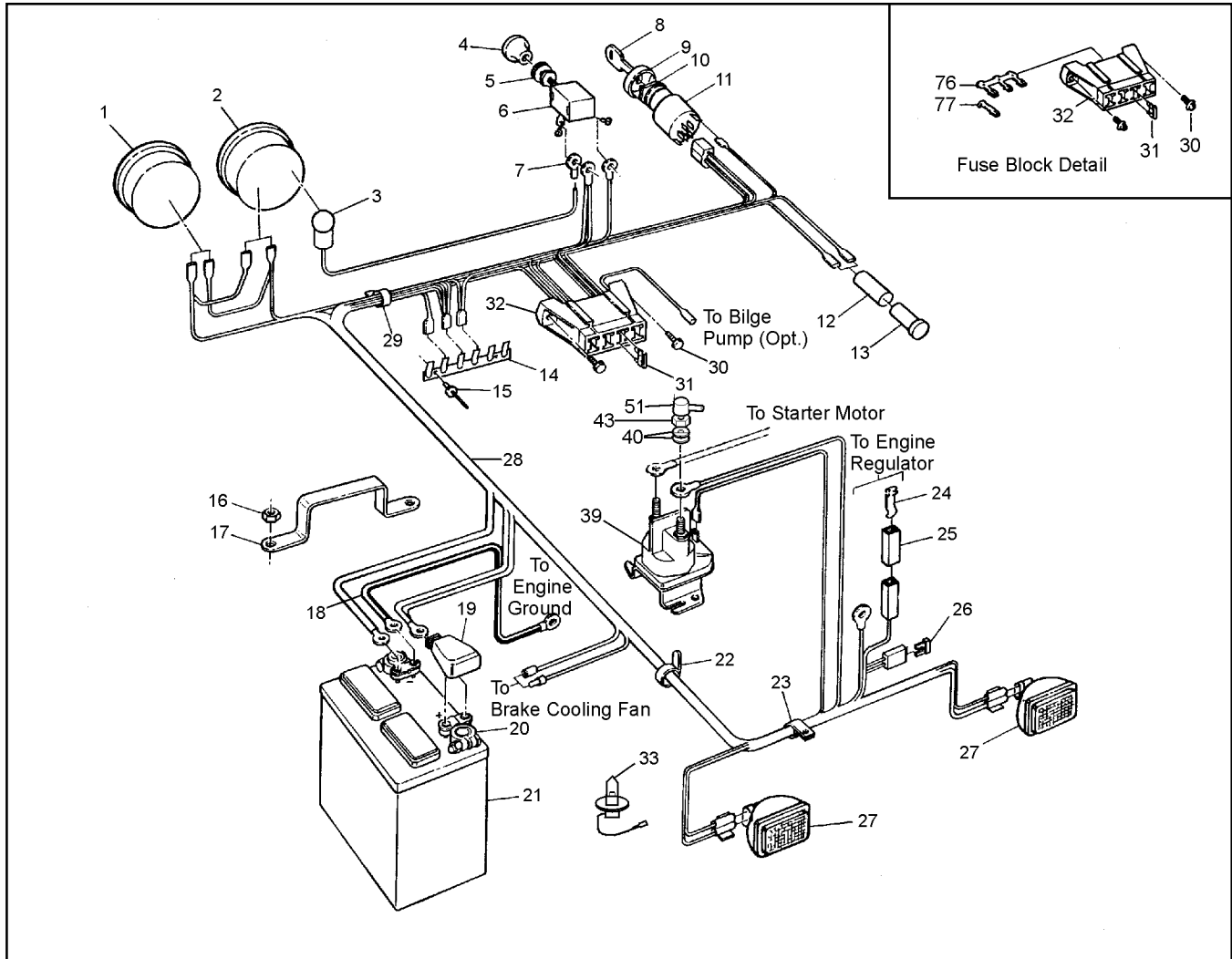

Ref.	Qty.	Part #	Description
1	1	632-15	Hourmeter #56458-10 (#876EM)
2	1	633-10	Voltmeter #07583-15 (#830EM)
3	2	634-10	Light Kit, #06215-00 5/8" dia, see Ref. 32 & 33 (opt.)
4	1	126-76	Knob, Light
5	1	108-55	Lockwasher 7/16 Ext. Tooth
6	1	100-62	Switch, Light
7	1	118-30	Terminal, Eye - #10
8	2	127-108	Key,molded
9	1	127-107	Cover, nut
10	1	127-106	Nut, flanged - plastic
11	1	127-105	Switch - Egnition
12	1	118-48	Heat Shrink
13	1	634-08	Light, Indicator
14	1	613-37	Terminal Strip, Ground
15	2	120-15	Rivet 1/8 x 7/16
16	2	117-21	Locknut, Nylon 5/16-18 Zinc
17	1	604-52	Bracket, Battery Retaining
18	1	613-14	Ground Wire
19	1	127-55	Cap, Battery Terminal - Red
20	2	127-56	Terminal, Battery Post
21	1	127-54	Battery
22	8	100-64	Tie Wrap - 5.5" - Black
23	10	126-93	Clamp, Nylon Wire - 1/2" ID
24	1	118-56	Contact
25	1	118-57	Connector Housing
26	1	118-51	Fuse, 30A 2-prong (AT030)
27	2	613-69	Headlamp, Halogen (incl. Ref. 33)
28	1	613-63	Wire Harness
29	1	127-24	Clamp, Nylon - 1" ID
30	2	112-51	Screw, IHWH T/C #10-24x5/8
31	4	118-49	Fuse, 15 A 2-prong (AT015)
32	1	118-60	Block Fuse - 8 position (4 fuse)
33	2	127-46	Bulb, Headlight - Halogen
39	1	613-68	Starter Relay
40	5	108-03	Lockwasher 1/4 Zinc
43	2	117-20	Nut, Fin. Hex 1/4-20 Zinc
51	1	613-45	Insulator, Terminal (6 ga.)
76	1	118-63	Terminal, Fuse - Triple
77	5	118-62	Terminal, Fuse - Single

ARGO Products Manufactured by:

Ontario Drive & Gear Limited

P.O. Box 280, 220 Bergey Court

New Hamburg, Ontario

Canada N0B 2G0

Phone: (519) 662-2840

Fax: (519) 662-2421

ODG *Dedicated to quality and performance*