

Argo
8x8 **Avenger**



ARGO

AVENGER

PARTS MANUAL

From Serial # V22271

Foreword

ODG has prepared this parts manual for the AVENGER model to assist both qualified mechanics and vehicle owners in ordering correct, quality replacement ARGO parts.

Proper and regular service, and replacing old, worn or broken parts with the correct ARGO replacement parts, are both essential to prolonging the life of the ARGO. Please refer to this parts manual before ordering any replacement part.

All information contained in this AVENGER Parts Manual is based on the latest product specification available at time of printing. If your AVENGER differs from the specifications contained in this manual, contact Ontario Drive & Gear Limited for information.

ODG reserves the right to alter specifications on the AVENGER model at any time, without obligation or prior notification.

Reproduction of this AVENGER Parts Manual, in whole or in part, is prohibited without prior written permission from Ontario Drive & Gear Limited.

Vehicle Identification

AVENGER - Serial Nos. V22271

Explanation of Parts Manual Format

- Ref** - Reference number between assembly diagram and component parts list
- Part No.** - Argo replacement part number for identification and re-ordering
- Description** - Part description for identification and re-ordering
- Qty** - Indicates the quantity of a part used in an assembly



Using the Parts Manual

1. Find the major vehicle assembly in the Table of Contents on this page, and turn to that section.
2. Locate the part in the illustration that you wish to order.
3. Refer to the parts list in that section.
4. Find the correct part number (Part No.), part description (Description) and correct quantity (Qty).
5. Use *only* this information to order ARGO replacement parts. *DO NOT* attempt to order a replacement part by reference number or page number.

Table of Contents	
Foreword	i
Vehicle Identification	i
Using the Parts Manual	ii
1.0 Transmission	1
2.0 Intake and Exhaust System	3
3.0 Clutch System	4
4.0 Power Pack Assembly	5
5.0 Steering & Brake System	7
6.0 Vehicle Body & Firewall	9
7.0 Frame & Drive System	11
8.0 Fuel System & Seat Assembly	13
9.0 Electrical System	15

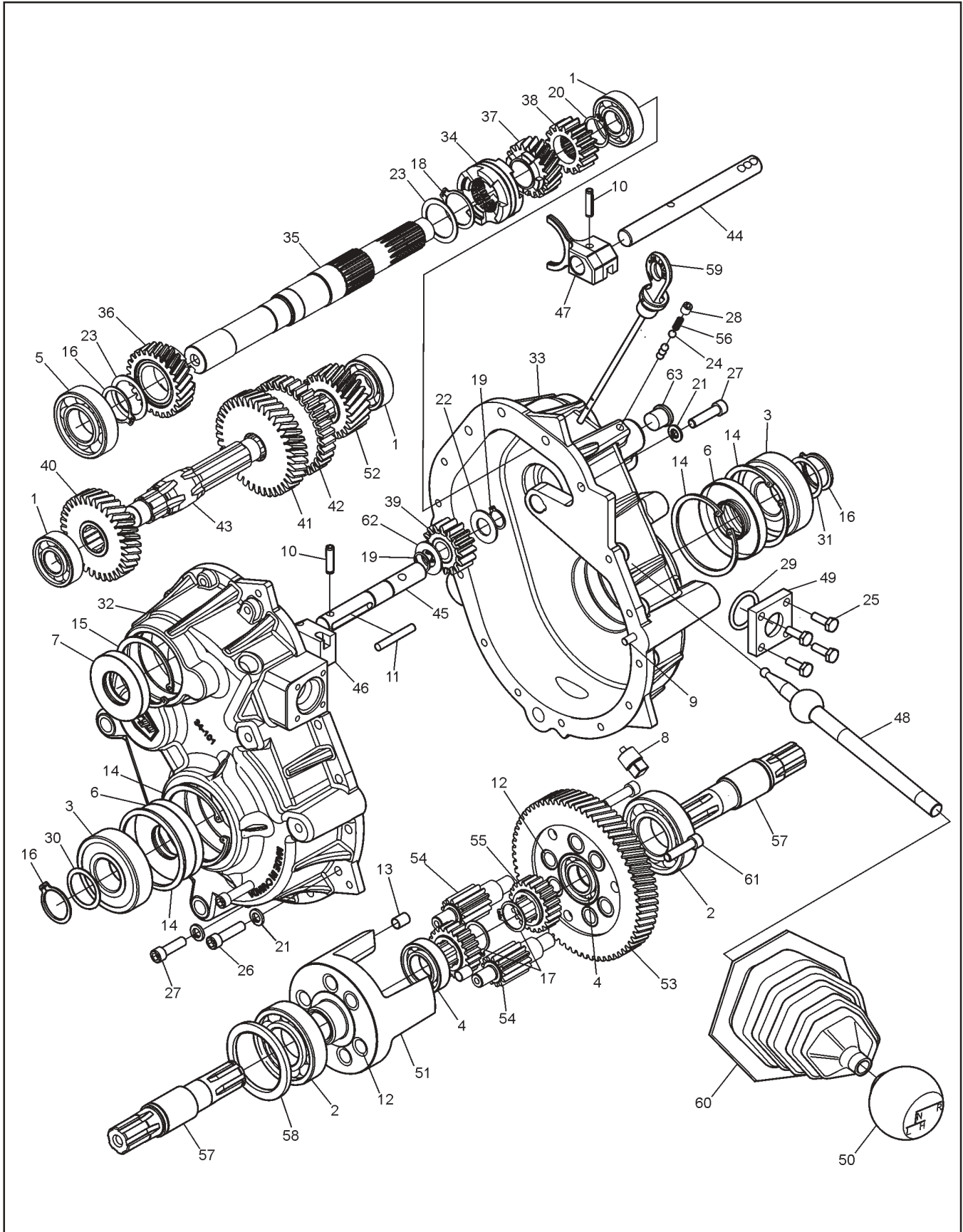

Avenger Parts Manual

1.0 Transmission

Ref.	Qty.	Part #	Description	Ref.	Qty.	Part #	Description
	1	34-100	Transmission Assembly	41	1	34-110	Gear, Helical - LOW 12DP 39T
1	3	101-01	Bearing, Ball 6204Z-C3	42	1	34-111	Gear, Reverse - 10DP 33T
2	2	101-03	Bearing, Ball 6207-C3	43	1	34-112	Shaft, Spline
3	2	101-05	Bearing, Ball 6306LLU-C3/2A	44	1	34-113	Shaft, Shift - Forward
4	2	101-15	Bearing, Ball 6005-C3	45	1	34-114	Shaft, Shift - Reverse
5	1	101-16	Bearing, Ball 6206-C3	46	1	34-115	Block, Shift
6	2	102-03	Seal,Oil WBS 30x72x10 NB D/LIP	47	1	34-116	Fork, Shift
7	1	102-05	Seal,Oil WBS 30x62x10 NB D/LIP	48	1	34-117	Lever, Shift
8	1	103-02	Plug, Magnetic 3/8-18NPT SQ.HD	49	1	34-118	Plate, Shifter
9	2	104-03	Pin, Dowel 1/4x7/8	50	1	34-121	Knob, Shift - w/Argo Logo
10	2	104-39	Pin, Spring - 1/4 x 1.0	51	1	34-122	Cage, Differential
11	1	104-40	Pin, Dowel - 1/4 x 1.75	52	1	34-123	Pinion, Helical - 25T
12	12	105-03	Bushing, Oilite - 1/2x3/4	53	1	34-124	Gear Plate - 66T
13	3	105-23	Bushing, Dowel - .312 x .5	54	6	34-13	Gear, Planet - 12T
14	4	106-03	Retaining Ring HO-281PA	55	2	34-14	Gear, Sun - 21T
15	1	106-05	Retaining Ring HO-244-PA	56	2	34-32	Spring, Comp. 0.22x.50
16	3	107-02	Retaining Ring SH-0118-PA	57	2	34-98	Shaft, Output - Splined
17	2	107-04	Retaining Ring SH-0098-PA	58	1	114-01	Washer, Shim 2.25 x 2.81 x .02
18	1	107-10	Retaining Ring SH-0125-PA	59	1	CE-035	Dipstick - with Breather - 190mm
19	2	107-11	Retaining Ring	60	1	609-38	Boot, Shifter
20	1	107-12	Retaining Ring SH-0100-PA	61	3	112-64	SHCS, 5/16-18 x 1.25
21	15	108-05	Lockwasher 5/16 Split-Ring Zn	62	1	108-81	Washer, Retaining Thrust
22	1	108-78	Washer, Thrust	63	1	113-14	Plug, Polyethylene - 5/8" Dia.
23	2	108-79	Washer, Thrust				
24	5	109-05	Ball, Steel 6mm 62-67 Rc				
25	4	112-04	HHCS 1/4-20x3/4 GR2 Zn				
26	13	112-143	SHCS 5/16 x 1.25 Zn				
27	2	112-144	SHCS 5/16 x 1.0 Zn				
28	1	112-145	SHSS 5/16 - 18 x 3/8				
29	1	113-11	O-Ring #AS568-216-70BN				
30	1	114-04	Washer, Shim 1.19x1.50x.04				
31	1	114-05	Washer, Shim 1.19x1.50x.02				
32	1	34-101	Housing, Transmission - L				
33	1	34-102	Housing, Transmission - R				
34	1	34-103	Clutch, Dog				
35	1	34-104	Shaft, Input - 19/15T Spline				
36	1	34-105	Pinion, Helical - HI 12DP 26T				
37	1	34-106	Pinion, Helical - LO 12DP 20T				
38	1	34-107	Pinion, Reverse - 10 DP 16T				
39	1	34-108	Gear, Idler - Rev - 10DP 16T				
40	1	34-109	Gear, Helical - HI 12DP 33T				

2.0 Intake and Exhaust System

Avenger Parts Manual

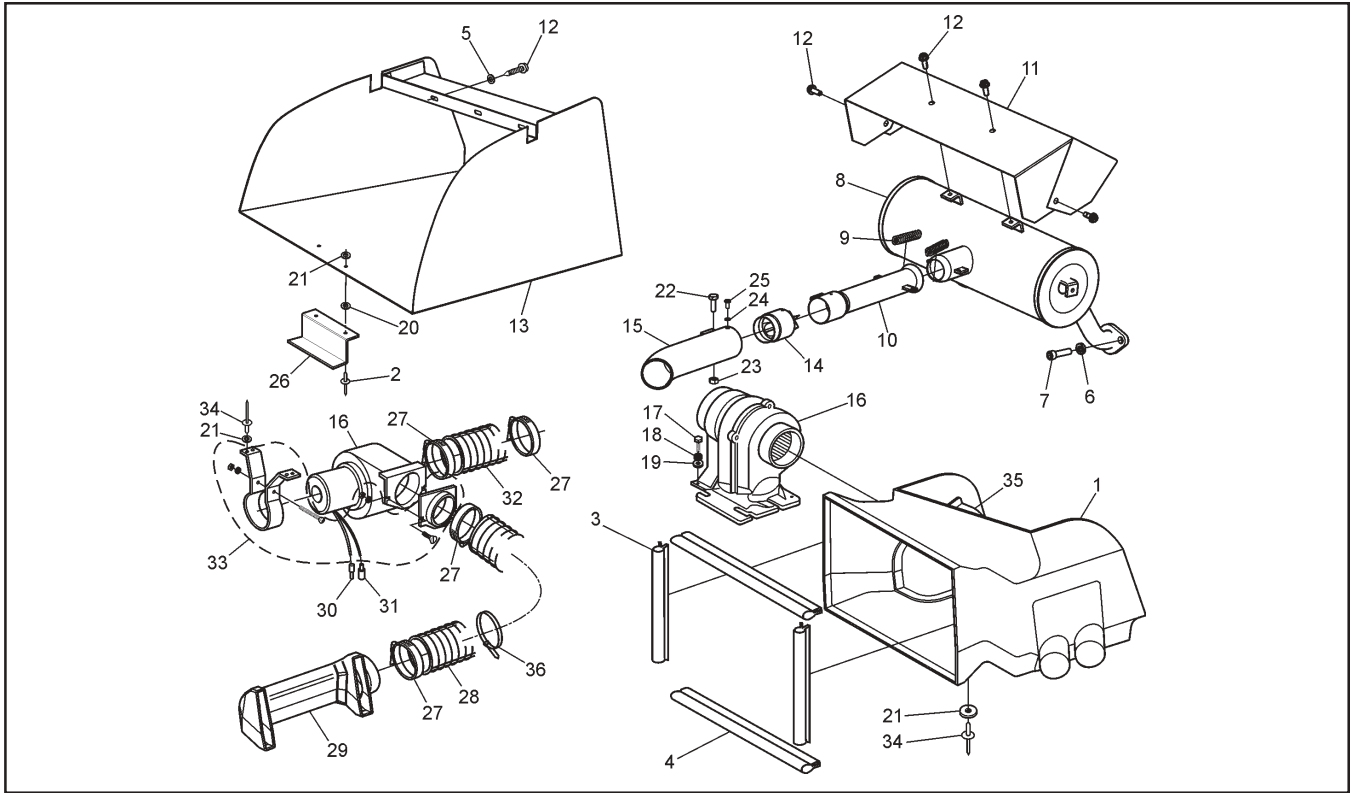

Ref.	Qty.	Part #	Description	Ref.	Qty.	Part #	Description
1	1	809-03	Duct, Intake	25	1	112-43	Screw IHWH #8 x 3/8
2	2	120-13	Rivet, 3/16 x 5/8 - Black	26	1	707-44	Support, Exhaust Duct - Avenger
3	2	809-05	Seal, Radiator - 10.25" LG	27	4	125-35	Clamp, Gear 3.50" HF-52
4	2	809-06	Seal, Radiator - 16.25" LG	28	1	127-139	Hose, Brake Fan Discharge
5	3	108-01	Washer, Fender 1/4 BS x1.25 OD	29	1	127-134	Duct, Brake Cooling
6	4	108-05	Lockwasher 5/16 Split Ring Zn	30	1	118-02	Terminal, Male #76-1251
7	4	117-73	Nut, M8x1.25 Zn	31	1	118-03	Terminal, Female #76-1289
8	1	607-105	Muffler	32	1	127-140	Hose, Brake Fan Inlet
9	2	126-57	Spring, Extension- 7/16x2.14	33		125-92	Adpt. & Mounting Kit - includes the following:
10	1	607-106	Pipe, Flared - Asm		1		Mounting Bracket
11	1	807-85	Shield, Heat - Muffler		1		Nut, #10-32
12	7	112-19	Screw, IHWH T/C Slot 1/4-20x1/2		1		Lockwasher, 3/16"
13	1	607-109	Duct, Exhaust		1		Screw, #10-32x2"
14	1	607-103	Spark Arrester		2		Nut, 1/4-20
15	1	607-107	Pipe, Tail - Asm		2		Lockwasher, 1/4"
16	1	125-91	Blower Fan		2		Screw, 1/4-20x5/8"
17	4	103-47	HHCS, #10-24x1/2		1		Adaptor, 3" dia.
18	4	120-05	Washer, .19x.50x.04	34	13	120-09	Rivet, 3/16 x 1.0 Black
19	4	108-59	Lockwasher #10 Int. Tooth	35	1	809-04	Shroud, Intake Duct
20	2	125-58	Washer, Fibre - W-77F	36	1	100-102	Tie Wrap, 14" - White
21	15	120-04	Washer, .19 x .50 x .08 Zn				
22	1	112-04	HHCS 1/4-20 x 3/4 Gr2 Zn				
23	1	117-81	Locknut, 2-way 1/4-20 Zn				
24	1	108-77	Lockwasher, #8 External Tooth				

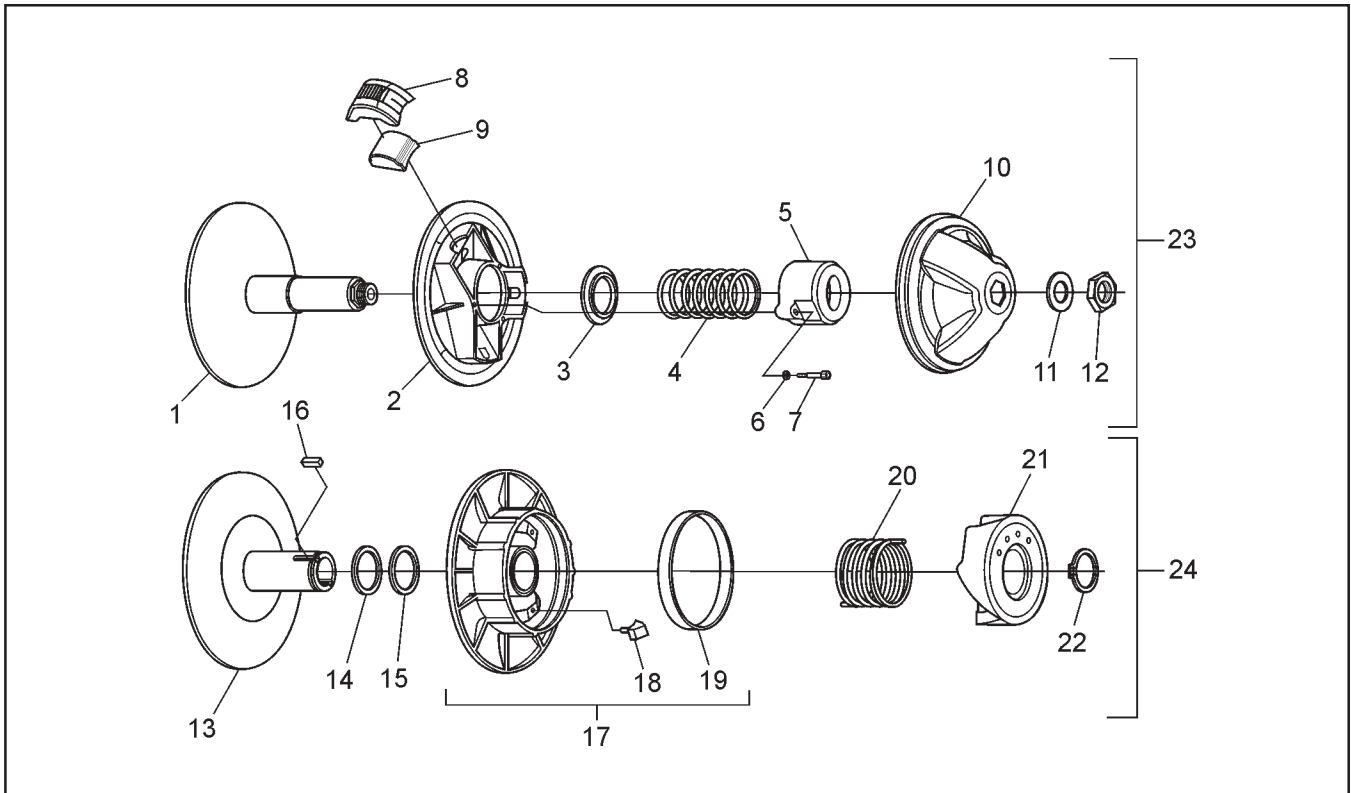

Ref.	Qty.	Part #	Description
1	1	0405-0075	Flange, Fixed
2	1	0410-0026	Flange, Sliding
3	1	0150-1014	Spring Guide Washer
4	1	0451-1114	Spring
5	1	0440-0005	Spring Cover
6	3	420-2453-700	Lockwasher
7	3	0080-0021	Screw, Cap
8	3	0130-3009	Block
9	3	0135-3065	Weight (275gr)
10	1	0115-3042	Cap
11	1	0080-0153	Washer, Zn
12	1	0080-0100	Nut
13	1	5105-0045	Flange, Fixed
14	1	ASA-1	Washer, Shim 1.2
15	as req	ASA-1-S	Washer, Shim 0.6
16	1	ASK-5	Key, Square
17	1	5110-0020	Flange, Sliding
18	3	ANS-2-T	Cam Shoe
19	1	5140-3006	Cam Bushing
20	1	5051-1110	Spring, Grey
21	1	5120-2043	Cam
22	1	371-9031-000	Retaining Ring, Outside
23	1	127-135	Clutch, Driver
24	1	127-136	Clutch, Driven

4.0 Power Pack Assembly

Avenger Parts Manual

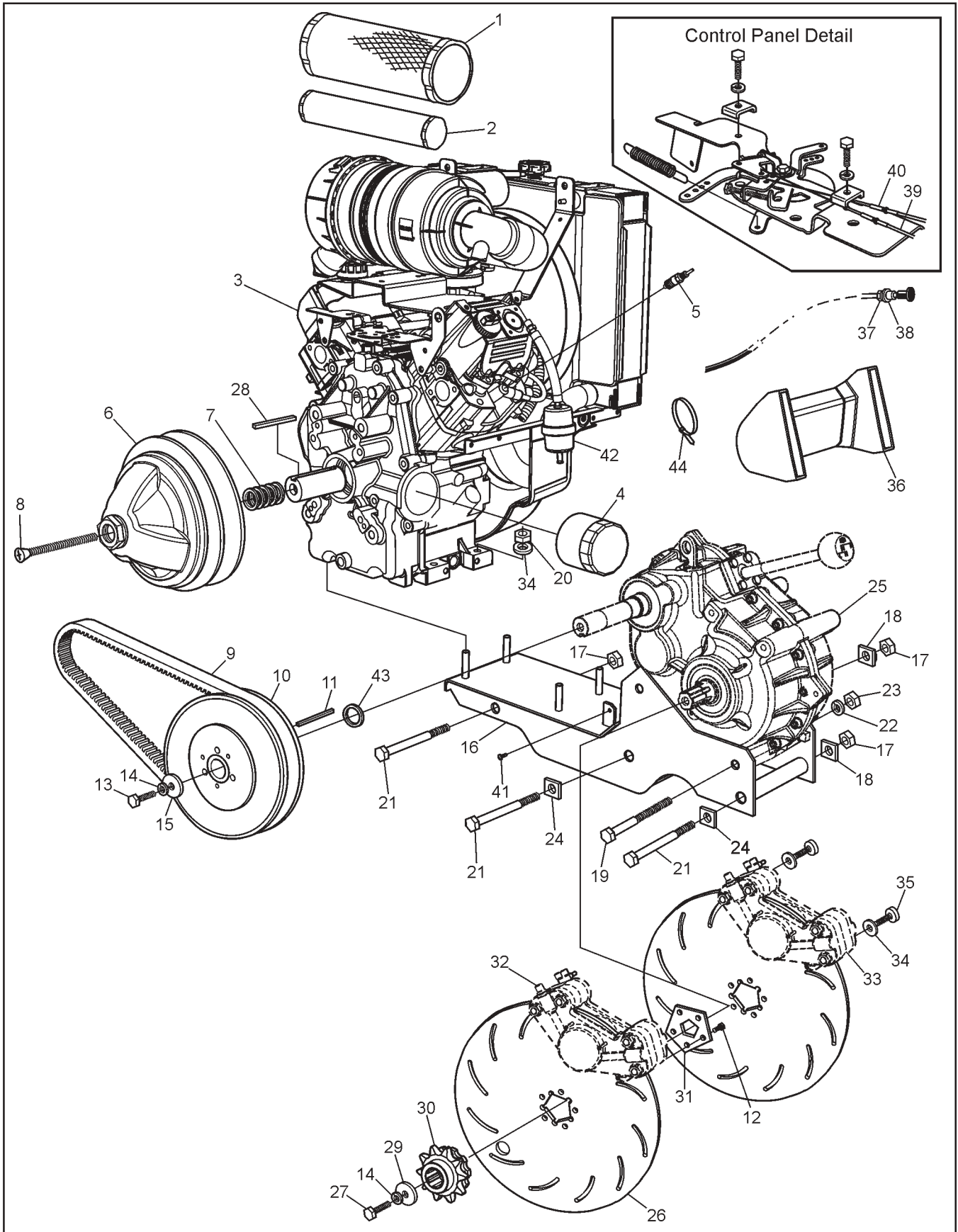

Avenger Parts Manual

4.0 Power Pack Assembly

Ref.	Qty.	Part #	Description	Ref.	Qty.	Part #	Description
1	1	25 083 01	Filter, Air	34	8	108-23	Washer .42 x .81 x .06 Gr8 Zn
2	1	25 083 04	Element, Inner	35	4	103-41	SHCS 3/8-16 x 1.25 Zn
3	1	LH 685	Kohler 25 HP Engine	36			See Section 2.0 Intake & Exhaust
4	1	1205001	Filter, Oil	37	1	117-68	Nut, Jam 3/8-24 UNF Zn
5		66 132 01	Sparkplug	38	1	108-32	Lockwasher 3/8 Int. Tooth
6			See Section 3.0 Clutch System	39	1	612-92	Cable Ass'y, Choke
7	5	114-04	Washer, Shim 1.19x1.50x.04	40	1	612-116	Cable Asm., Throttle – Avenger
8	1	112-152	FHSC, 7/16-20 x 4.0" LG	41	2	103-71	Screw, IHWH T/C 1/4-20 x 1.25 Zn
9	1	127-137	Drive Belt - 10.5" Cen. Dist	42	1	24050 02	Filter, Fuel
10			See Section 3.0 Clutch System	43	as req	108-36	Washer, 1.03 x 1.37 x .06 Zn
11	1	110-09	Key 1/4 x 1/4 x 30	44	2	100-102	Tie Wrap - 14" - White
12	5	112-153	HHCS, 1/4-20 x 1/2" Gr8 Zn				
13	1	103-34	HHCS 3/8-16 x 1.25 Gr5 Zn				
14	3	108-06	Lockwasher 3/8 Split Ring Zn				
15	1	108-46	Washer .40 x 1.37 x 1.2 Hi- Carbon				
16	1	806-35	Frame Ass'y - Power Pack				
17	3	117-09	Locknut, Nylon 5/8-11 Zn				
18	2	811-09	Washer, Square - .64 ID				
19	2	103-20	HHCS 1/2-13 x 6.5 Gr5 Zn				
20	4	117-29	Locknut, Nylon 3/8-16 Zn				
21	3	112-58	HHCS 5/8-11 x 7.5 Gr5 Zn				
22	2	108-07	Lockwasher 1/2 Split Ring Zn				
23	2	117-06	Nut, Fin Hex 1/2-13 Zn				
24	2	811-15	Washer, Square Lock .64 ID				
25			See Section 1.0 Transmission				
26	2	606-73	Disc, Brake-10.2" Dia., 5 Bolt				
27	2	103-18	HHCS 3/8-24 x 1.25 Gr5 Zn				
28	1	110-13	Key 1/4 x 1/4 x 2.25				
29	2	108-18	Washer .40 x 1.37 x .12 Zn				
30	2	606-71	Sprocket, Drive 10T #60				
31	2	108-80	Retainer, Brake Disc - 5 Bolt				
32			See Section 5.0 Steering & Brake System				
33			See Section 5.0 Steering & Brake System				

5.0 Steering & Brake System

Avenger Parts Manual

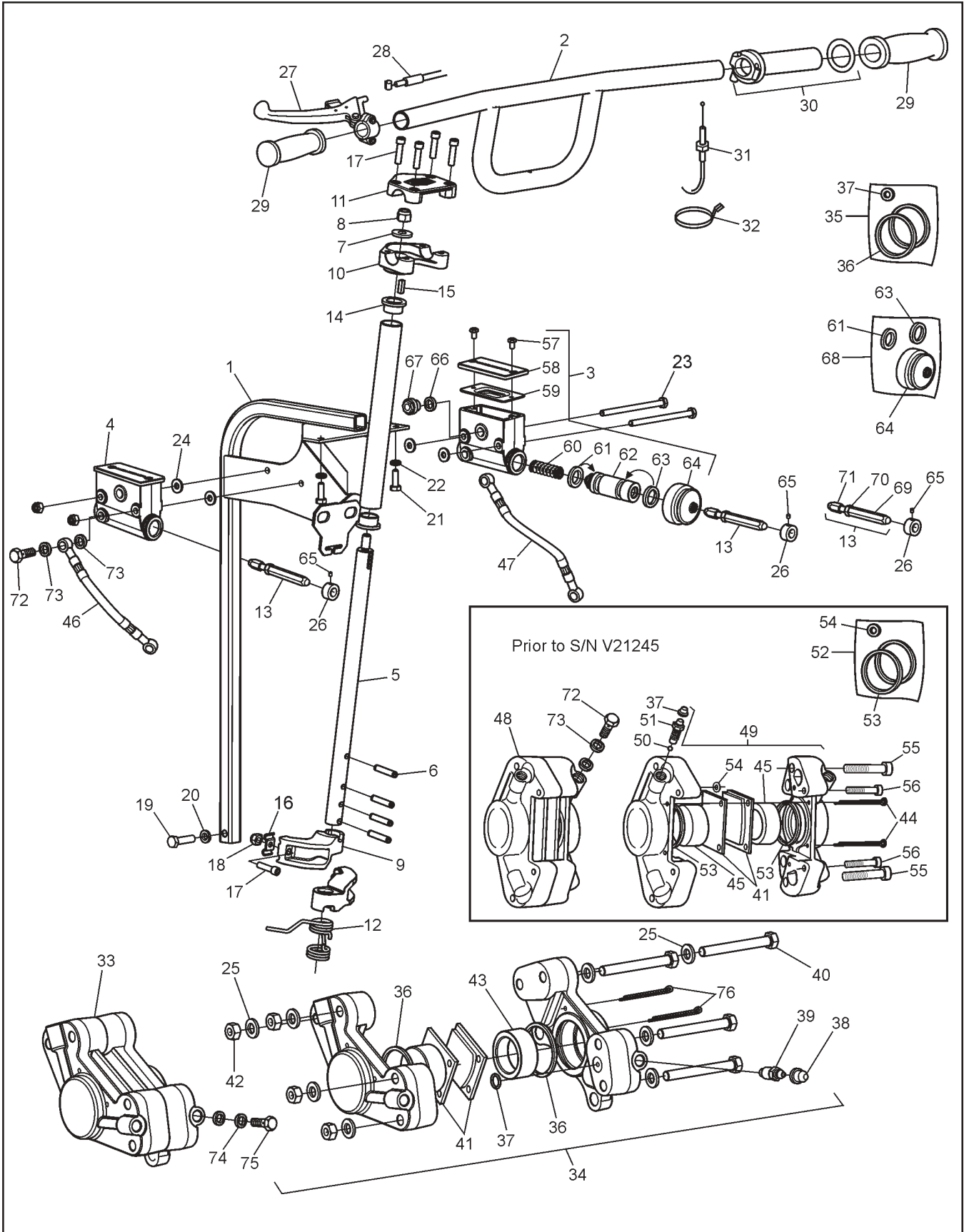

Avenger Parts Manual

5.0 Steering & Brake System

Ref.	Qty.	Part #	Description	Ref.	Qty.	Part #	Description
1	1	612-110	Frame Assembly, Steering Column	46	1	163-03	Hose Asm, Hydraulic - Left - Avenger
2	1	612-107	Handlebar Assembly	47	1	163-04	Hose Asm, Hydraulic - Right - Avenger
3	1	165-05	Master Cylinder - R	48	1	166-01RM	*Caliper, Hydraulic Brake - L, w/o pads
4	1	165-06	Master Cylinder - L	49	1	166-02RM	*Caliper, Hydraulic Brake - R, w/o pads
5	1	612-104	Shaft, Steering - Argo	50	2x1	109-03	*Ball, Steel - 7/32 Dia.
6	4	104-07/PI	Pin, Spring 1/4 x 1.25	51	2x1	168-03	*Screw, Bleeding M10 x 1,0
7	1	108-47	Washer, .39 x .94 x .13 Zn Di-chr	52	2	161-01	*O-Ring Kit, Caliper
8	1	117-29	Locknut, Nylon 3/8-16 Zn	53	2		*Seal, Piston - 41mm
9	2	612-102	Arm, Steering	54	1		*Seal, Rubber - 5mm
10	1	612-106	Clamp, Lower Handlebar	55	2x2	160-41	*SHCS M10 x 1,5 x 50mm Zn
11	1	612-105	Clamp, Upper Handlebar	56	2x2	160-40	*SHCS M8x1,25 x 40 Zn
12	2	612-103	Spring, Handlebar Centering	57	2x2	160-42	FHMS M5x0,8x6mm
13	2	812-13	Pin Assembly, Plunger - Adjustable	58	2x1	168-08	Cover
14	2	105-16	Bushing, Oilite - 3/4 x 1/2	59	2x1	168-09	Cover, Rubber
15	1	110-17	Key, 3/16 x 3/16 x .625	60	2x1	162-02	Spring, Comp. 0.59x1.5
16	2	128-10	Retainer, Handbrake Cable	61	2x1		Seal, Primary, 19mm (See Ref. 68)
17	6	112-47	SHCS, 1/4-20 x 1.0 Zn	62	2x1	168-10	Piston 19mm dia.
18	4	117-27	Locknut, Nylon 1/4-20 Zn	63	2x1		Seal, Secondary, 19mm (See Ref. 68)
19	1	103-38	HHCS 5/16-18 x 1.25 Gr5 Zn	64	2x1		Boot, Rubber (See Ref. 68)
20	1	108-05	Lockwasher 5/16 Split-Ring Zn	65	2	112-02	SHSS 10-24x1/4 Knurl Cup PT, PL
21	2	112-04	HHCS 1/4-20 x 3/4 Gr2 Zn	66	2x1	160-03	O-ring, Oil Window
22	2	108-17	Lockwasher 1/4 Int Tooth Zn	67	2x1	168-14	Oil Window, Master Cylinder
23	2	103-66	HHCS, 1/4-20 x 4.0 Gr5 Zn	68	2x1	161-25	O-Ring Kit - Master Cylinder (incl. Ref. 61, 63 & 64)
24	4	108-08	Washer, .28 x .62 x .04 Zn	69	1	812-14	Pin, Female
25	2x8	108-24	Washer, .34 x .70 x .06 Zn	70	1	117-20	Nut, Fin Hex 1/4-20 Zn
26	2	812-17	Collar	71	1	812-15	Fin, Male
27	1	128-08	Lever Assembly, Handbrake	72	2	160-44	Bolt, Banjo - M10 x 1,0 x 21,0
28	1	128-09	Cable Assembly, Handbrake		2	160-44	*Bolt, Banjo - M10 x 1,0 x 21,0
29	2	127-35	Grip, Molded	73	4	160-01	Washer, Copper - 1,5 x 10,0 x 14,0
30	1	127-81	Throttle Twist Grip		4	160-01	*Washer, Copper - 1,5 x 10,0 x 14,0
31	1	612-116	Cable Asm., Throttle - Avenger	74	4	160-04	**Washer, Copper 2.3 x 10.0 x 16.0
32	1	100-64	Tie Wrap - 5.5" - Black	75	2	160-45	**Banjo Bolt
33	1	166-10	**Caliper, Hydraulic Brake -L w/o pads	76	2x2	168-07	Pin, Cotter 1/8 x 3.00 Zn
34	1	166-11	**Caliper, Hydraulic Brake -R w/o pads				* Prior to S/N V21245
35	2	161-05	O-ring Kit, Knott Caliper				** From S/N V21245
36	2		Seal, Rubber				
37	2		Seal, Piston				
38	2x1	168-20	Plug, Rubber				
39	2x1	168-02	Screw, Bleeding, Knott Caliper				
40	2x4	112-154	SHCS, 3/8-16 x 2.75 Zn				
41	1	170-03	Pad Set (4), Brake - Non-Asbestos				
42	2x4	117-03	Nut, Fin Hex 5/16-18 Zn				
43	2x2	168-01	Piston, Knott Caliper				
44	2x2	168-06	*Pin, Cotter 3,2 x 50mm				
45	2x2	168-05	*Piston 41mm				

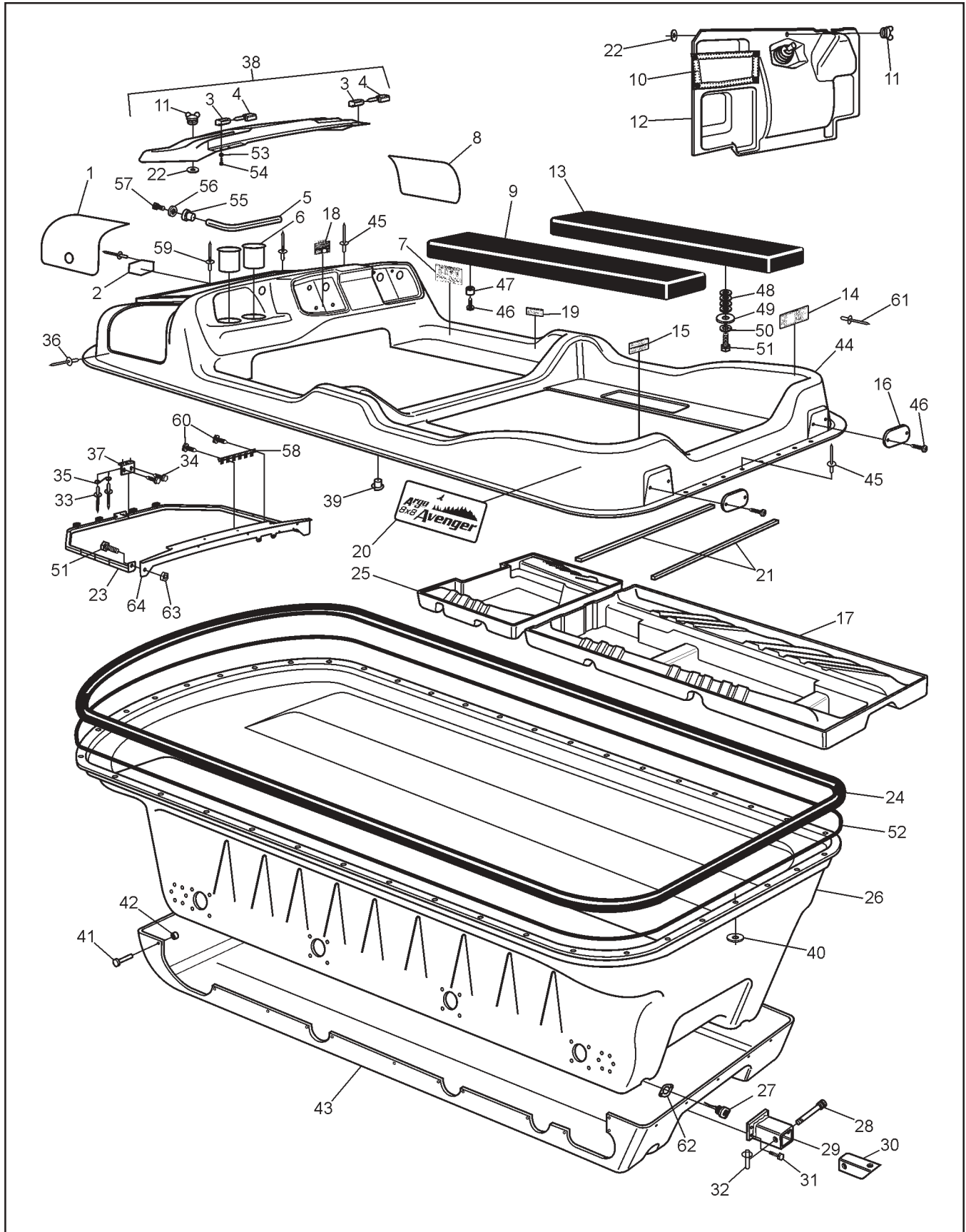

Avenger Parts Manual

6.0 Vehicle Body & Firewall

Ref.	Qty.	Part #	Description	Ref.	Qty.	Part #	Description
1	1	707-43	Screen - Exhaust - Avenger	40	54	120-04	Washer .19 x .50 x .08 Zn
2	1	601-44	Nameplate, "Argo"	41	32	120-27	Pin, Magna Grip
3	2	127-45B	Knuckle, Hinge	42	32	120-28	Collar, Magna Grip
4	2	127-45A	Pin, Hinge	43	1	801-51	Skid Plate, 8x8 - Black
5	1	601-101	Tube, Dash Handle	44	1	801-52	Body & Hood, Upper -
6	2	100-109	Cup holder Insert				Avenger (spec. colour) (incl.
7	1	126-68	Plate, Operation				23, 33, 34, 35, 37, 38)
8	1	707-42	Screen, Intake - Avenger	45	80	120-09	Rivet 3/16 x 1 - Black
9	1	608-64	Seat, Rear - Left	46	8	103-48	T/S Pan HD PHIL #10 x 5/8
10	1	100-108	Mesh, Glove Box	47	4	126-79	Bumper, Plastic - Black
11	2	126-10	Wing Stud	48	16	108-25	Washer .31 x .75 x .06 Zn
12	1	803-60	Firewall, Avenger	49	4	801-41	Washer, Seat
13	1	608-65	Seat, Rear - Right	50	4	108-03	Lockwasher 1/4
14	1	126-67	Plate, Floor Pan	51	6	112-04	HHCS 1/4-20 x 3/4 Gr2 Zn
15	1	127-142	Plate, Vehicle Capacity -	52	1	126-60	Vinyl Strip, 1/2" x 1/4" x 37.5'
			Avenger	53	8	108-59	Lockwasher #10 Int. Tooth Zn
16	2	127-01	Reflector, Red	54	8	103-47	HHCS 10-24 x 1/2
17	1	803-58	Floor Pan, Rear - Avenger	55	1	113-12	Insert, 1/2-13
18	1	127-141	Label, Caution - Keyswitch	56	1	108-35	Washer .53 x 1.06 x .09 Zn
19	1	126-69	Plate, Fuel	57	1	112-151	HHCS 1/2-13 x 1" Gr2 Zn
20	2	127-138	Nameplate - Avenger	58	1	613-37	Terminal Strip, Ground
21	2	601-09	Trim, Vinyl - 28"	59	14	120-13	Rivet, 3/16 x 5/8 Black
22	2	126-09	Grommet, Alum. Flattened	60	2	112-139	OHPS T/S #4 x 5/8 Black Zn
			Half	61	30	120-24	Rivet, 3/32 x 3/8 Alum. (all
23	1	602-49	Frame Ass'y, Hood - Front				plates)
24	1	801-05	Bumper, Vinyl - 8x8	62	2	100-114	Gasket, Drain Plug
25	1	803-59	Floor Pan, Front - Avenger	63	2	117-82	Locknut, Flange 1/4-20 Zn
26	1	801-50	Body, Lower - Avenger	64	1	602-51	Frame Ass'y, Hood - Rear
27	2	100-107	Plug, Drain - Flanged				
28	1	104-13	Pin, Toplink - 3/4 x 2.75				
29	1	616-16	Hitch Assembly				
30	1	616-19	Tube, Hitch				
31	4	103-82	HHCS 3/8-16 x 1.5 Gr5 Zn				
32	1	104-11	Pin, Lynch - Ring				
33	4	120-15	Rivet - 1/8 x 7/16				
34	2	103-72	Screw, IHWH T/C Slot				
			1/4-20x3/4				
35	1	126-11	Spring, Retaining				
36	28	120-11	Rivet 5/32 x 9/16 - Black				
37	1	601-69	Plate, Spring				
38	1	602-47	Hood Kit - Avenger (spec.				
			colour) (incl.3, 4, 11, 22, 53, 54)				
39	2	117-44	T- Nut 1/4-20 Zn				

7.0 Frame and Drive System

Avenger Parts Manual

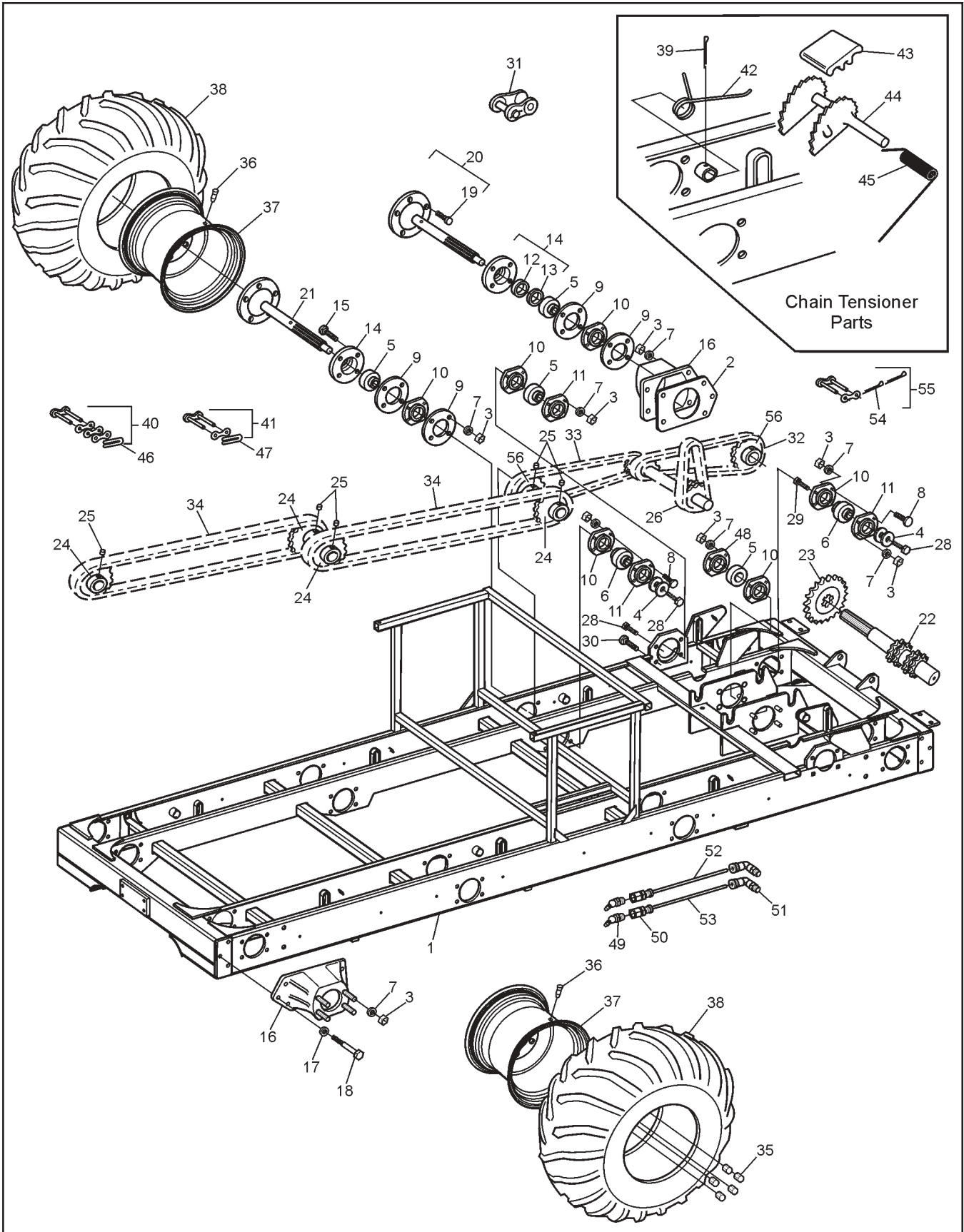

Ref.	Qty.	Part #	Description
1	1	806-10	Frame Asm - Avenger
2	4	606-25	Gasket - Bearing Extension
3	80	117-29	Locknut, Nylon 3/8-16 Zn
4	16	108-46	Washer .40 x 1.37 x .12 Hi-Carbon
5	12	101-35	Bearing, Ball - 1.25
6	8	101-41	Bearing, Ball - 1.0
7	82	108-15	Washer, .42 x .81 x .05 Zn
8	31	103-88	C/Bolt 3/8-16 x 1.0 Gr5 Zn
9	16	605-89	Gasket, Flange - Outer
10	20	605-63	Flange - 4 hole
11	10	101-20	Flange, Greasable - 4 hole
12	8	102-14	Seal, Oil 1.25 x 1.75 x 0.188
13	8	102-15	Seal, Oil 1.25 x 1.874 x 0.25
14	8	605-97	Flange Asm, Outer (incl. Refs. 12 & 13)
15	16	112-39	C/Bolt 3/8-16 x 1.75 Gr5 Zn
16	4	810-91	Bearing Extension
17	20	108-34	Washer .47 x .94 x .06 Zn
18	20	112-150	HHCS 7/16-20 x 1.5 Gr5 Zn
19	5x8	103-80	Stud, Wheel 7/16-20 x 1.125 #B271
20	4	810-73	Axle Asm - Front/Rear (incl. Ref. 19)
21	4	810-75	Axle Asm - Mid (incl. Ref. 19)
22	2	810-32	Shaft, Idler - 11T
23	2	606-72	Sprocket, Idler S60 x 21T
24	8	606-34	Sprocket, S60 x 19T
25	10	112-03	SHSS 5/16-18 x 3/8 1/2 DOG, PL
26	2	803-54	Chain, Idler RC60-1 x 34P (incl. Ref. 55)
28	12	112-31	HHCS 3/8-16 x 1.0 2B Gr8 Zn
29	1	103-82	HHCS 3/8-16 x 1.5 Gr5 Zn
30	4	112-61	C/Bolt 3/8-16 x 1.25 Gr5 Zn
31		127-80	Link, Half - RC60 - 1 (opt.)
32	2	803-55	Chain, RC50-2 x 46P-Front (incl. Ref. 40)
33	2	803-56	Chain, RC50-2 x 74P-Mid (incl. Ref. 40)
34	4	803-57	Chain, RC60-1 x 90P-Rear (incl. Ref. 41)
35	5x8	117-35	Nut, Wheel 7/16-20 Zn
36	8	125-26	Valve, Tire
37	8	127-61C	Rim - 10 x 9 - Charcoal
38	8	127-100SA	Tire, Rawhide III 25 x 11.50-9
39	8	100-01	Pin, Cotter 1/8 x 1.50 Zn
40	1x4	100-96	Con. Link, RC50-2 H.D.
41	1x4	603-84	Con. Link, RC60-1 H.D.
42	8	127-65	Spring Torsion - 1.16x0.35
43	8	606-39	Slider Block -1/2" Shaft
44	8	606-35	Tensioner Asm, Chain
45	8	127-64	Spring, Torsion - .76 x 1.9
46	4	603-95	Spring Clip - RC 50 Closed
47	6	603-96	Spring Clip - RC 60 Closed
48	2	101-78RM	Flange, Greasable - 1/8 NPT-RM
49	2	100-110	Fitting, Grease - 1/8 NPT
50	2	100-111	Fitting, Bulkhd - 1/8 NPTF x 5/32 Tube
51	2	100-112	Fitting, 1/8 NPTM x 5/32 Tube x 90
52	1	100-113L	Tubing, 5/32 Grease x 3.5"
53	1	100-113R	Tubing, 5/32 Grease x 4.5"
54	4	104-35	Pin, Cotter 2mm x 12mm
55	2	603-94	Con. Link, RC60-1 Cotter Pin
56	4	810-28	Spacer, Double - 24T

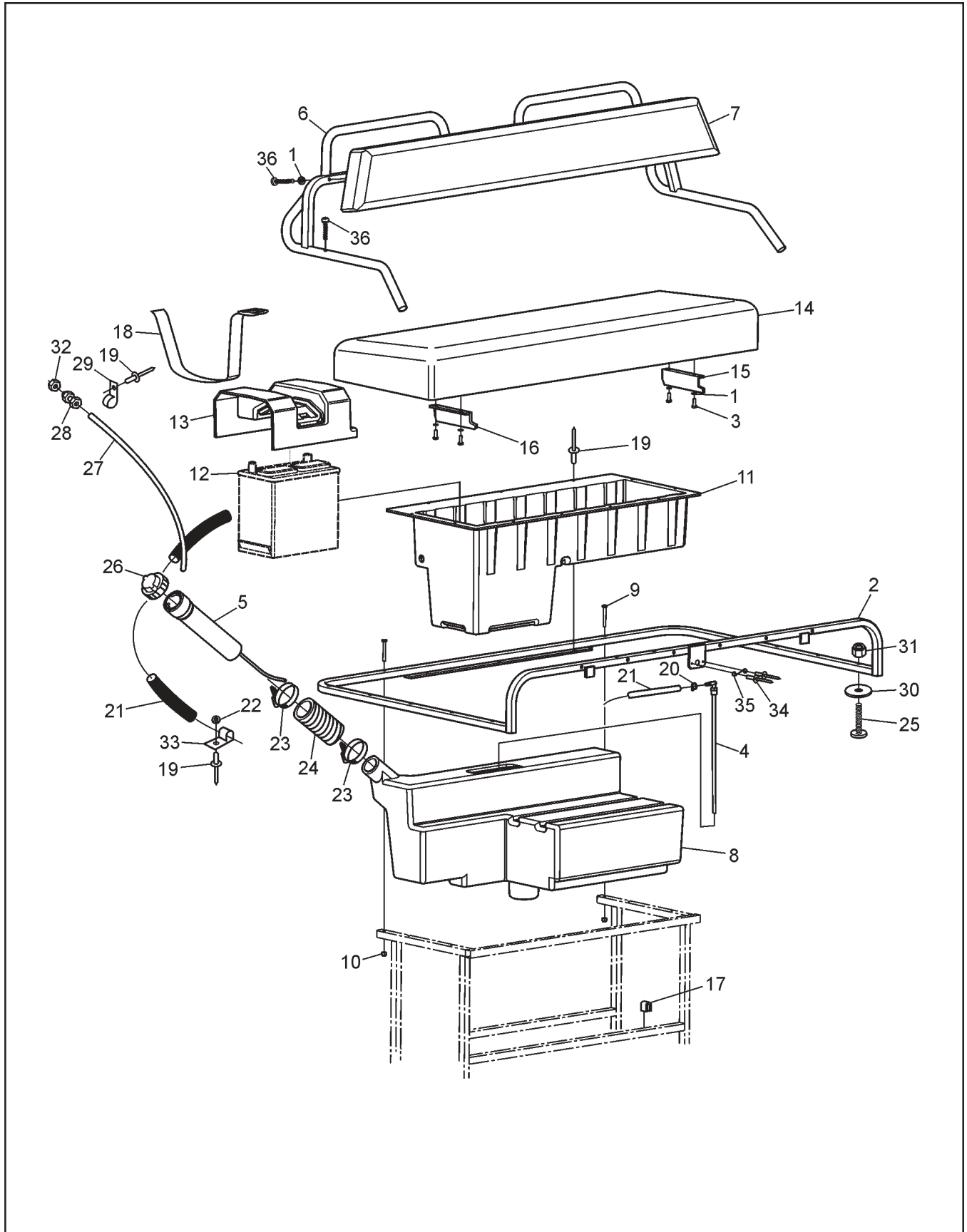

Avenger Parts Manual 8.0 Fuel System & Seat Assembly

Ref.	Qty.	Part #	Description
1	8	108-03	Lockwasher 1/4 Split Ring Zn
2	1	608-61	Frame Assembly, Seat
3	4	112-04	HHCS 1/4-20x3/4 Gr2 Zn
4	1	608-52	Tube Assembly, Fuel Pick-up
5	1	608-59	Neck Assembly, Vented Filler
6	1	608-47	Frame Assembly, Backrest
7	1	608-39	Back pad Assembly
8	1	608-44	Tank, Fuel - Argo
9	2	103-77	HHCS, 1/4-28 X 2.0
10	2	117-01	Locknut, Nylon 1/4-28 Zn
11	1	608-54	Toolbox
12	1	127-54P	See Section 9.0 Electrical System
13	1	608-55	Cover, Battery
14	1	608-45	Seat Assembly, Bench
15	1	608-57	Retainer, Seat - Left
16	1	608-58	Retainer, Seat - Right
17	6	702-06	Foam Cushion
18	1	608-56	Strap, Battery
19	19	120-09	Rivet 3/16x1 - Black
20	4	112-79	Clamp, Hose, 1/2" - Black
21	1	608-66	Hose, Fuel - 80"
22	2	120-04	Washer .19 x .50 x .08 Zn
23	2	100-12	Clamp, Gear 2.25" HF-36
24	1	125-94	Hose, Filler
25	10	112-07	RHMS 10-24x1.50 Zn
26	1	126-46	Cap, Fuel
27	1	127-21	Hose, Vent - 86"
28	1	126-50	Male Connector, 1/4"
29	6	126-94	Clamp, Nylon Wire - 1/4"ID
30	10	108-42	Washer .21x1.0x.06 Zn
31	10	117-10	Locknut, Nylon #10-24 Zn
32	1	117-54	Nut, Locking PAL 1/2-20 Zn
33	3	126-93	Clamp, Nylon Wire - 1/2"ID
34	2	120-15	Rivet, 1/8 x 7/16
35	1	126-11	Spring
36	6	112-41	PHMS, Phil 1/4-20 x 1.25 Zn

9.0 Electrical System

Avenger Parts Manual

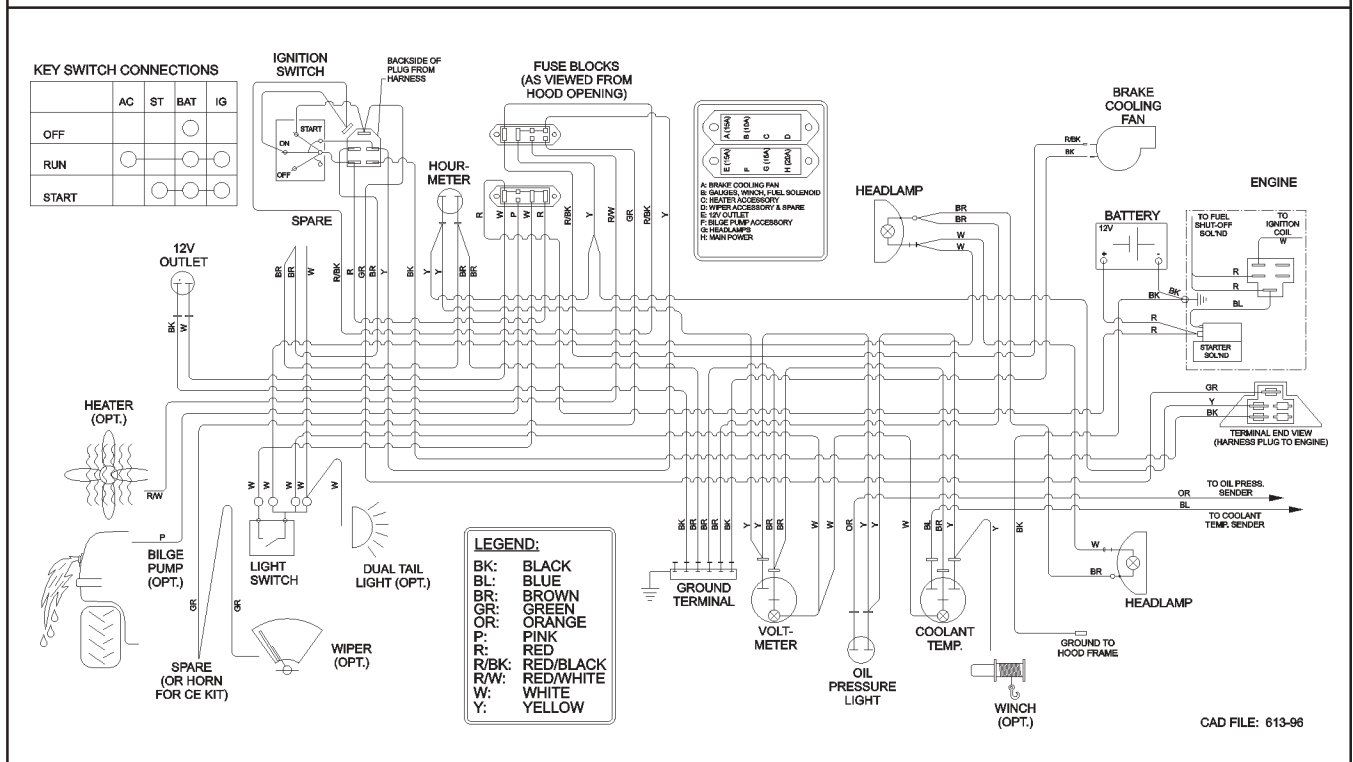
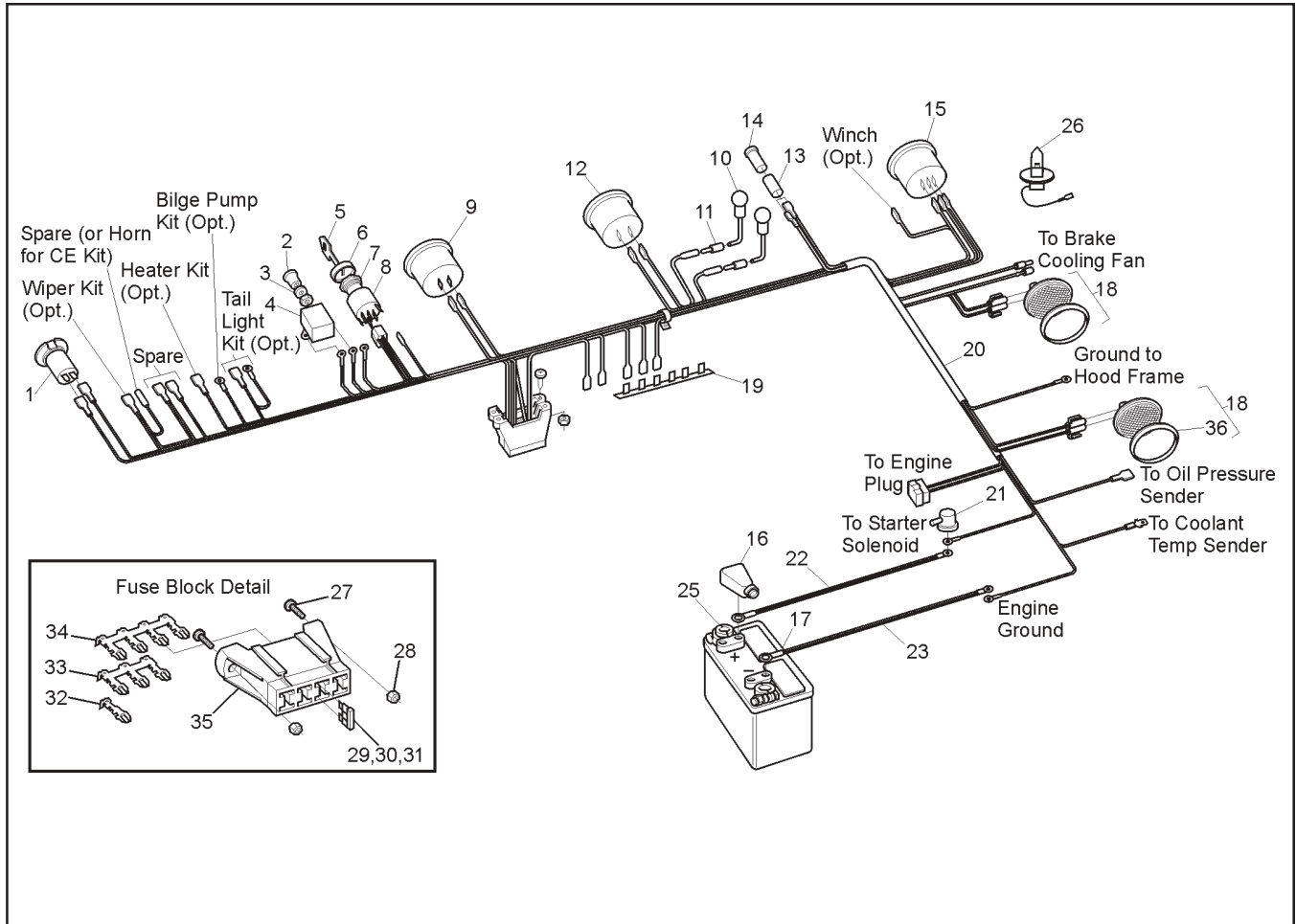

CAD FILE: 613-96

Ref.	Qty.	Part #	Description
1	1	613-90	Outlet, 12 Volt DC
2	1	126-76	Knob, Light - Black
3	1	108-55	Lockwasher 7/16 Ext. Tooth Zn
4	1	100-62	Switch, Light
5	2	127-108	Key, Molded
6	1	127-107	Bezel - Cover, Nut
7	1	127-106	Nut, Flanged - Plastic
8	1	127-105	Switch - Ignition
9	1	632-15	Hourmeter #85005C-22
10	2	634-10	Light Kit, #06215-00 5/8" Dia.
11	3	118-02	Terminal, Male #76-1251
12	1	633-10	Voltmeter #07583-15 (#830EM)
13	2	118-48	Heat Shrink 2" x 1/2 Dia.
14	3	634-08	Light, Indicator
15	1	634-23	Gauge, Water Temp. - Avenger
16	1	127-55	Cap, Battery Terminal - Red
17	1	127-54	Battery, Exide 45-50
18	2	613-92	Headlamp Ass'y - Oval w/Bezel (incl. items 26 & 36)
19	2	613-37	Terminal Strip, Ground
20	1	613-96	Wire Harness, Kohler 25HP
21	1	613-46	Insulator, Terminal (2 ga.)
22	1	613-94	Wire, Positive Battery
23	1	613-95	Wire, Negative Battery
24	1	681-00	FOB, Key - Floating (not shown)
25	2	127-56	Terminal, Battery Post
26	2	127-46	Bulb, Headlight - Halogen 37W
27	4	103-25	PHMS #10-24x3/4 Zn
28	4	117-10	Locknut, Nylon #10-24 Zn
29	1	118-52	Fuse, 10A 2 Prong (AT010)
30	3	118-49	Fuse, 15A 2 Prong (AT015)
31	1	118-53	Fuse, 20A 2 Prong (AT020)
32	9	118-62	Terminal - Fuse, single
33	1	118-63	Terminal - Fuse, triple
34	1	118-61	Terminal - Fuse, quad
35	2	118-60	Block - Fuse, 8 position (4 fuse)
36	2	613-93	Bezel, Headlamp - Avenger

ARGO Products Manufactured by:

Ontario Drive & Gear Limited

220 Bergey Court
New Hamburg, Ontario
Canada N3A 2J5
Phone: (519) 662-2840
Fax: (519) 662-2421

ODG *Dedicated to quality and performance*