



# **ARGO**

## **JIM SHOCKEY**

*Signature Series*

# **PARTS MANUAL**

From Serial # ...26300

# Foreword

ODG has prepared this parts manual for the AVENGER model to assist both qualified mechanics and vehicle owners in ordering correct, quality replacement ARGO parts. For the most current parts manual visit our website at [www.argoatv.com](http://www.argoatv.com).

Proper and regular service, and replacing old, worn or broken parts with the correct ARGO replacement parts, are both essential to prolonging the life of the ARGO. Please refer to this parts manual and/or our website [www.argoatv.com](http://www.argoatv.com) before ordering any replacement part.

All information contained in this AVENGER Parts Manual is based on the latest product specification available at time of printing. If your AVENGER differs from the specifications contained in this manual, check our website [www.argoatv.com](http://www.argoatv.com) for the most current information.

ODG reserves the right to alter specifications on the AVENGER model at any time, without obligation or prior notification.

Reproduction of this AVENGER Parts Manual, in whole or in part, is prohibited without prior written permission from Ontario Drive & Gear Limited.

## Vehicle Identification

**AVENGER** - Serial Nos. ...26300

## Explanation of Parts Manual Format

- |                    |                                                                      |
|--------------------|----------------------------------------------------------------------|
| <b>Ref</b>         | - Reference number between assembly diagram and component parts list |
| <b>Part No.</b>    | - Argo replacement part number for identification and re-ordering    |
| <b>Description</b> | - Part description for identification and re-ordering                |
| <b>Qty</b>         | - Indicates the quantity of a part used in an assembly               |



### Using the Parts Manual

1. Find the major vehicle assembly in the Table of Contents on this page, and turn to that section.
2. Locate the part in the illustration that you wish to order.
3. Refer to the parts list in that section.
4. Find the correct part number (Part No.), part description (Description) and correct quantity (Qty).
5. Use *only* this information to order ARGO replacement parts. **DO NOT** attempt to order a replacement part by reference number or page number.

### Table of Contents

Foreword .....	i
Vehicle Identification.....	i
Using the Parts Manual .....	ii
1.0 Transmission .....	1
2.0 Intake and Exhaust System.....	3
3.0 Clutch System .....	5
4.0 642-42 Brush Guard Kit.....	6
5.0 Power Pack Assembly .....	7
6.0 Steering & Brake System .....	9
7.0 Parking Brake .....	11
8.0 Vehicle Body & Firewall.....	13
9.0 Frame & Drive System .....	15
10.0 Fuel System & Seat Assembly .....	17
11.0 Electrical System .....	19

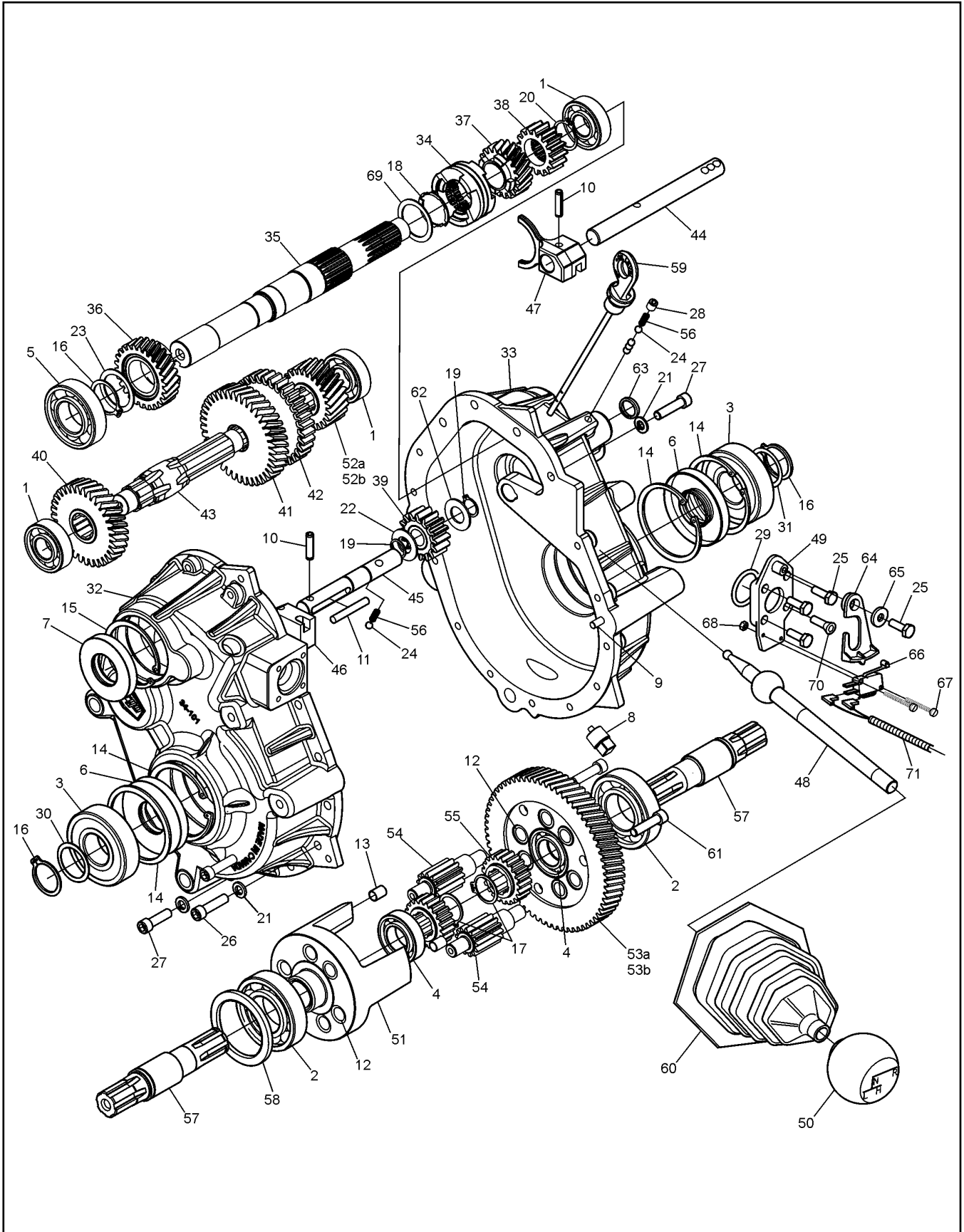

# Avenger Parts Manual

# 1.0 Transmission

Ref.	Qty.	Part #	Description	Ref.	Qty.	Part #	Description
	1	34-100	Transmission Assembly	40	1	34-109	Gear, Helical - HI 12DP 33T
	1	34-100-3.3	Transmission Assembly	41	1	34-110	Gear, Helical - LOW 12DP 39T
1	3	101-01	Bearing, Ball 6204Z-C3	42	1	34-111	Gear, Reverse - 10DP 33T
2	2	101-03	Bearing, Ball 6207-C3	43	1	34-112	Shaft, Spline
3	2	101-05	Bearing, Ball 6306LLU-C3/2A	44	1	34-113	Shaft, Shift - Forward
4	2	101-15	Bearing, Ball 6005-C3	45	1	34-114	Shaft, Shift - Reverse
5	1	101-16	Bearing, Ball 6206-C3	46	1	34-115	Block, Shift
6	2	102-03	Seal,Oil WBS 30x72x10 NB D/LIP	47	1	34-116	Fork, Shift
7	1	102-05	Seal,Oil WBS 30x62x10 NB D/LIP	48	1	34-117	Lever, Shift
8	1	103-02	Plug, Magnetic 3/8-18NPT SQ.HD	49	1	34-131	Plate, Shifter
9	2	104-03	Pin, Dowel 1/4x7/8	50	1	34-121	Knob, Shift - w/Argo Logo
10	2	104-39	Pin, Spring - 1/4 x 1.0	51	1	34-122	Cage, Differential
11	1	104-40	Pin, Dowel - 1/4 x 1.75	52a	1	34-123	Pinion, Helical - 25T - 2.6
12	12	105-03	Bushing, Oilite - 1/2x3/4	52b	1	34-125	Pinion, Helical - 21T - 3.3
13	3	105-23	Bushing, Dowel - .312 x .5	53a	1	34-124	Gear Plate - 66T - 2.6
14	4	106-03	Retaining Ring HO-281PA	53b	1	34-126	Gear Plate - 70T - 3.3
15	1	106-05	Retaining Ring HO-244-PA	54	6	34-13	Gear, Planet - 12T
16	3	107-02	Retaining Ring SH-0118-PA	55	2	34-14	Gear, Sun - 21T
17	2	107-04	Retaining Ring SH-0098-PA	56	2	34-32	Spring, Comp. 0.22x.50
18	1	107-14	Retaining Ring LC-125-PA	57	2	34-98	Shaft, Output - Splined
19	2	107-11	Retaining Ring	58	1	114-01	Washer, Shim 2.25 x 2.81 x .02
20	1	107-15	Retaining Ring SHR-098-PA	59	1	CE-035	Dipstick - with Breather - 190mm
21	15	108-05	Lockwasher 5/16 Split Ring Zn	60	1	609-38	Boot, Shifter
22	1	108-78	Washer, Thrust	61	3	112-64	SHCS, 5/16-18 x 1.25
23	1	108-79	Washer, Thrust	62	1	108-81	Washer, Retaining Thrust
24	5	109-05	Ball, Steel 6mm 62-67 Rc	63	1	113-16	O-Ring #AS568-014-70BN 5/8"OD x 1/2"ID x 1/16" Thk
25	4	112-04	HHCS 1/4-20x3/4 Gr2 Zn	64	1	34-132	Follower, Neutral Start
26	14	112-143	SHCS 5/16 x 1.25 Zn	65	1	108-08	Washer, .28 x .62 x .07 Zn
27	1	112-144	SHCS 5/16 x 1.0 Zn	66	1	809-202	Switch, Limit - Two Pole
28	1	112-145	SHSS 5/16 - 18 X 3/8	67	2	112-172	SHMS, #5-40x3/4 Zn
29	1	113-11	O-Ring #AS568-216-70BN	68	2	117-173	Locknut, #5-40 Zn
30	1	114-04	Washer, Shim 1.19x1.50x.04	69	1	108-85	Washer, Retaining Thrust
31	1	114-05	Washer, Shim 1.19x1.50x.02	70	1	112-171	FHSC 1/4-20 x 3/4 Gr2 Zn
32	1	34-101	Housing, Transmission - L	71	1	613-112	Wire Harness, Neutral Start
33	1	34-102	Housing, Transmission - R				
34	1	34-127	Clutch, Dog				
35	1	34-130	Shaft, Input - 19/15T Spline				
36	1	34-128	Pinion, Helical - HI 12DP 26T				
37	1	34-129	Pinion, Helical - LO 12DP 20T				
38	1	34-107	Pinion, Reverse - 10DP 16T				
39	1	34-108	Gear, Idler - Rev - 10DP 16T				

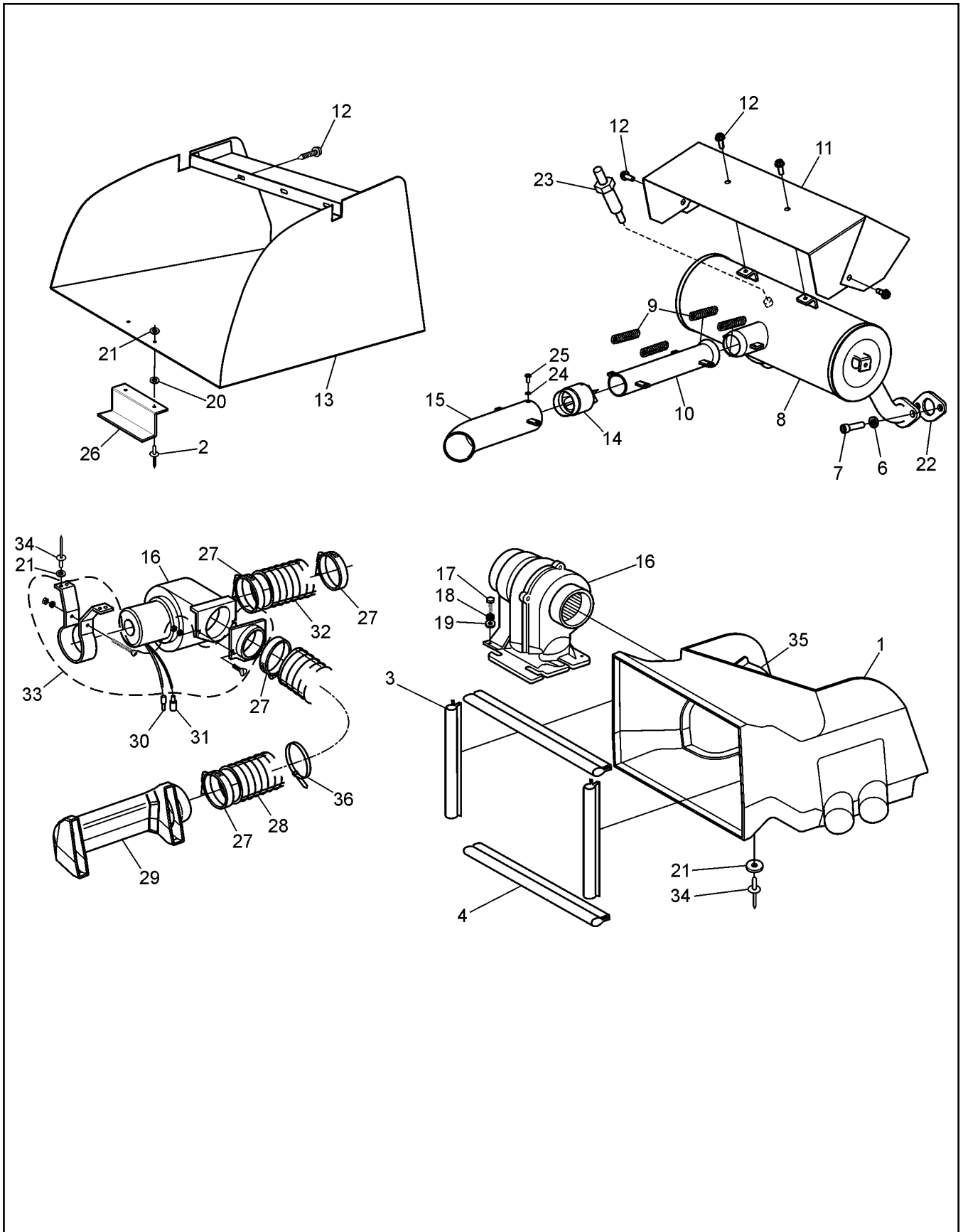

Ref.	Qty.	Part #	Description
1	1	809-03	Duct, Intake
2	2	120-13	Rivet, 3/16 x 5/8 - Black
3	2	809-05	Seal, Radiator - 10.25" LG
4	2	809-06	Seal, Radiator - 16.25" LG
6	4	108-05	Lockwasher 5/16 Split Ring Zn
7	4	112-30	SHCS M8 x 1,25 x 20mm Zn
8	1	607-119	Muffler Ass'y, Avenger 1.25
8a	1	607-121	Muffler Ass'y, Avenger EFI
9	4	126-57	Spring, Extension- 7/16 x 2.14
10	1	607-125	Tube Ass'y, Muffler, Flared
11	1	807-85	Shield, Heat - Muffler
11a	1	607-123	Shield, Heat - Muffler - EFI
12	7	112-19	Screw, IHWH T/C Slot 1/4-20 x 1/2
13	1	607-109	Duct, Exhaust
14	1	607-126	Spark Arrester, 1.75 Dia.
15	1	607-117	Pipe, Tail - Asm
16	1	125-91	Blower Fan
17	4	103-47	HHCS, #10-24 x 1/2
18	4	120-05	Washer, .19 x .50 x .04
19	4	108-59	Lockwasher #10 Int. Tooth
20	2	125-58	Washer, Fibre - W-77F
21	14	120-04	Washer, .19 x .50 x .08 Zn
22	2	24 041 49	Gasket, Exhaust Manifold
23	1		<b>See Section 4.0 Power Pack Assembly</b>
24	1	108-77	Lockwasher, #8 External Tooth
25	1	112-43	Screw IHWH #8 x 3/8
26	1	707-44	Support, Exhaust Duct - Avenger
27	4	125-35	Clamp, Gear 3.50" HF-52
28	1	127-139	Hose, Brake Fan Discharge
29	1	127-134	Duct, Brake Cooling
30	1	118-02	Terminal, Male #76-1251
31	1	118-03	Terminal, Female #76-1289
32	1	127-140	Hose, Brake Fan Inlet
33	1	125-92	Adpt. & Mounting Kit - includes the following:
	1		Mounting Bracket
	1		Nut, #10-32
	1		Lockwasher, 3/16"
	1		Screw, #10-32x2"
	2		Nut, 1/4-20
	2		Lockwasher, 1/4"
	2		Screw, 1/4-20x5/8"
	1		Adaptor, 3" dia.
34	13	120-09	Rivet, 3/16 x 1.0 Black
35	1	809-04	Shroud, Intake Duct
36	1	100-102	Tie Wrap, 14" - White

# 3.0 Clutch System

# Avenger Parts Manual

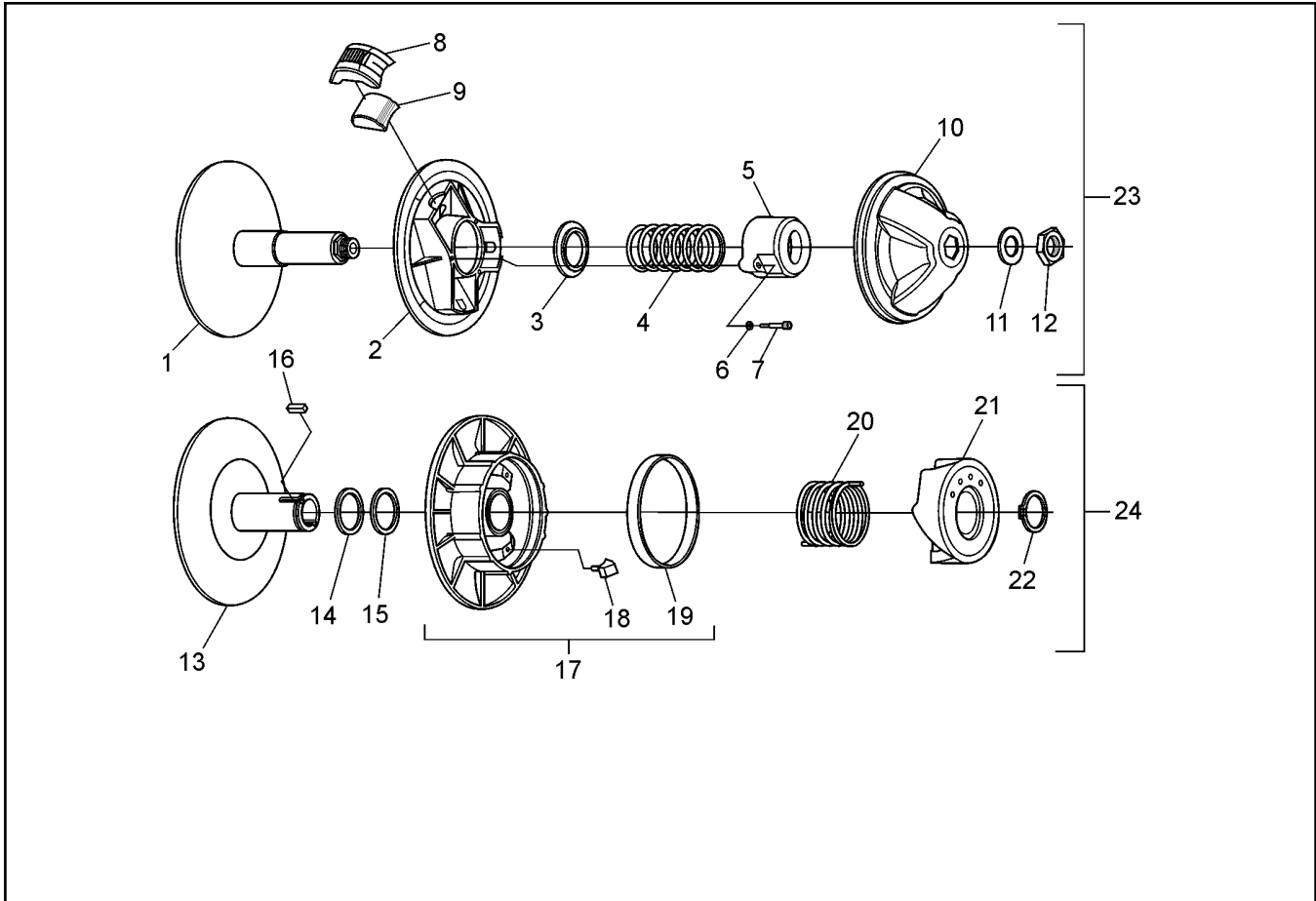

Ref.	Qty.	Part #	Description	Ref.	Qty.	Part #	Description
1	1	0405-0075	Flange, Fixed	19	1	5950-3003	Spring Protector
2	1	0410-0026	Flange, Sliding	20	1	5950-3002	Spring Support
3	1	0150-1014	Spring Guide Washer	21	1	0080-0216	Retaining Ring, Outside
4	1	0451-1114	Spring	22	2	0080-0167	Lockwasher
5	1	0440-0005	Spring Cover	23	1	127-157	Clutch, Driver - EFI Models
6	3	0080-0167	Lockwasher		1	127-135	Clutch, Driver
7	3	0080-0021	Screw, Cap	24	2	0080-0035	Screw & Nut Ass'y
8	3	0130-3009	Block	25	1	127-156	Clutch, Driven - INVANCE
9	3	0135-3065	Weight (275gr)				
	3	0135-3062	Weight (240gr) - EFI Model				
10	1	0115-0047	Cap				
11	1	0080-0153	Washer, Zn				
12	1	0080-0100	Nut				
13	1	5905-0003	Flange, Fixed				
14	1	0080-0164	Washer, Shim				
15	1	5910-0002	Flange, Sliding				
16	3	5930-3001	Cam Shoe				
17	2	0080-0031	Screw				
18	1	5951-1009	Spring				



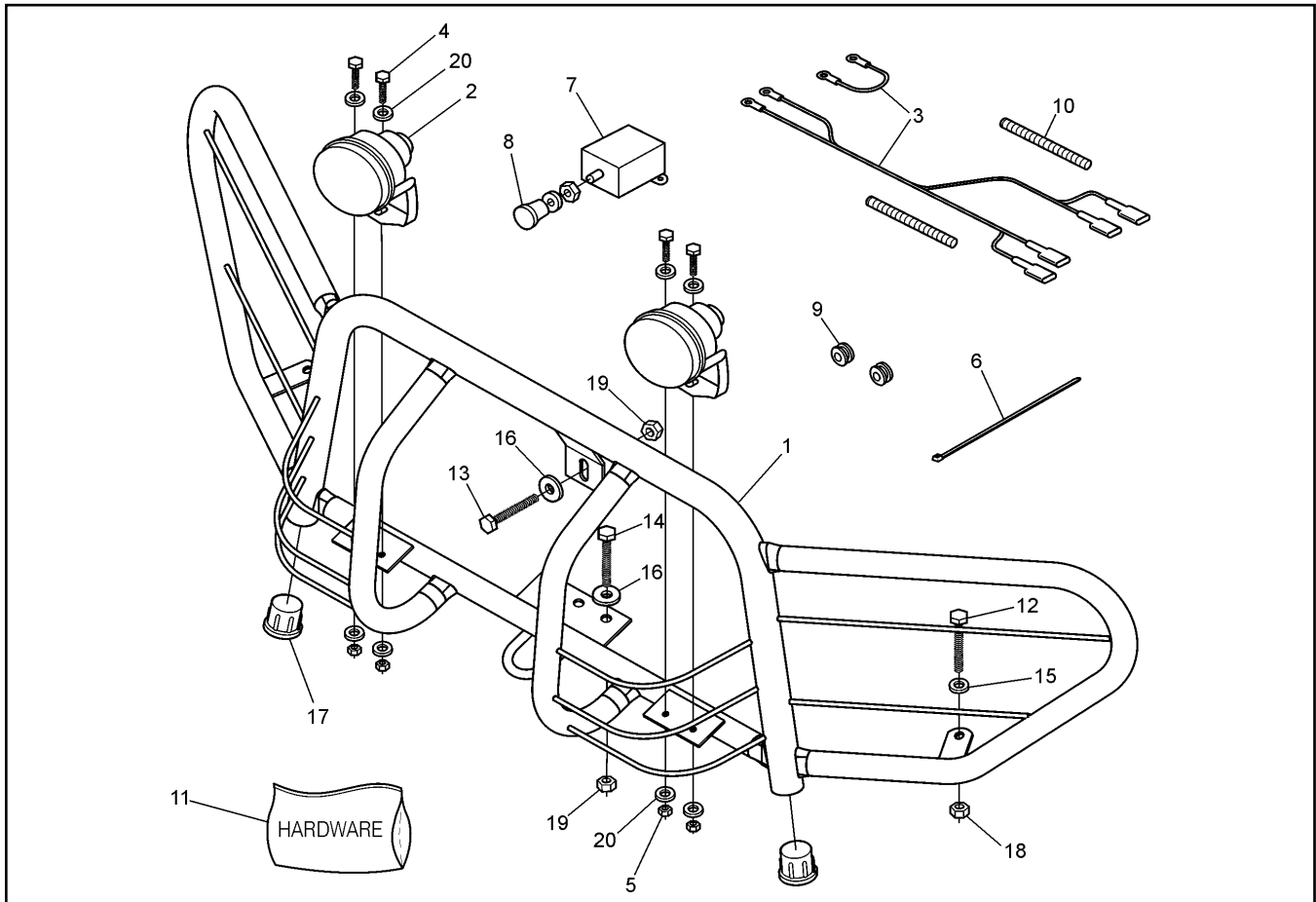

Ref.	Qty.	Part #	Description
1	1	642-41	Brush Guard Weldment, Jim Shockey
2	2	613-110	Light, Fog
3	1	613-109	Wire Harness, Fog Light
4	4	103-25	PHMS 10-24 x 3/4 Zn
5	4	117-10	Locknut, 10-24 N/I Zn
6	6	100-64	Tie Wrap - 5.5" - Black
7	1	100-62	Switch, Light
8	1	126-76	Knob, Light - Black
9	2	125-84	Grommet, Rubber
10	9"	810-90RM	Loom, Nylon - .500" ID
11	1	<b>642-20HDW</b>	<b>Hardware Kit comprised of:</b>
12	2	103-57	HHCS 5/16-18 x 1.5 Gr5 Zn
13	1	103-76	HHCS 3/8-16 x 1.75 Gr5 Zn
14	3	103-82	HHCS 3/8-16 x 1.5 Gr5 Zn
15	2	108-12	Washer .34 x 1.00 x .06 Zn
16	7	108-18	Washer .40 x 1.37 x .12 Zn
17	2	113-13	Plug, 1-1/4" Tube - Avg Brush Guard
18	2	117-21	Locknut, Nylon 5/16-18 Zn
19	4	117-29	Locknut, Nylon 3/8-16 Zn
20	8	120-05	Washer .19 x .50 x .04 Zn

# 5.0 Power Pack Assembly

# Avenger Parts Manual

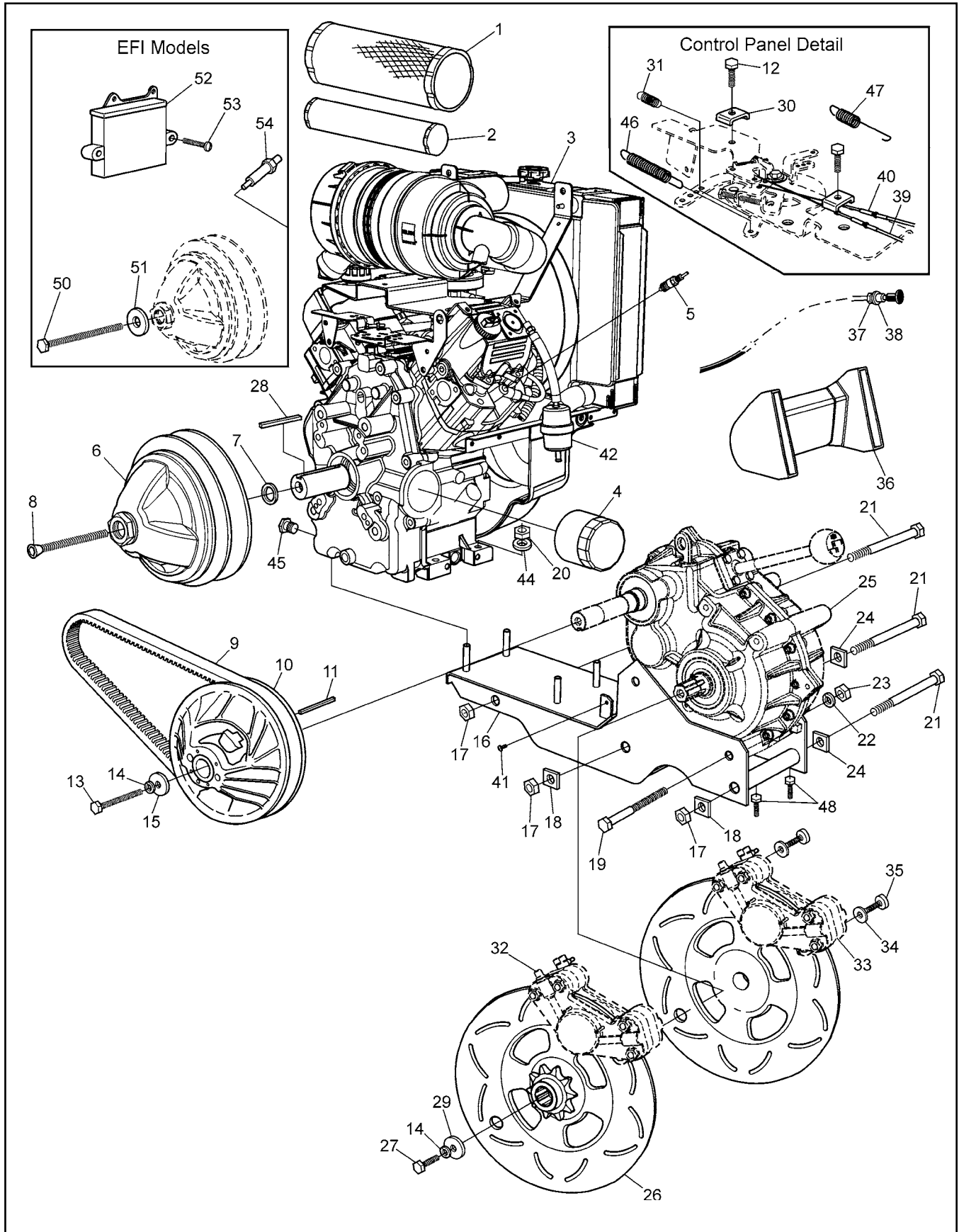

# Avenger Parts Manual

# 5.0 Power Pack Assembly

Ref.	Qty.	Part #	Description	Ref.	Qty.	Part #	Description
1	1	25 083 01	Filter, Air	34	4	108-23	Washer .42 x .81 x .06 Gr8 Zn
2	1	25 083 04	Element, Inner	35	4	103-41	SHCS 3/8-16 x 1.25 Zn
3	1	LH690-0014	Kohler 26 HP Engine	36			<b>See Section 2.0 Intake &amp; Exhaust</b>
3a	1	LH775	Kohler 31 HP Engine, EFI	37	1	117-68	Nut, Jam 3/8-24 UNF Zn
4	1	12 050 01	Filter, Oil	38	1	108-32	Lockwasher 3/8 Int. Tooth
5		66 132 01	Sparkplug	39	1	612-92	Cable Ass'y, Choke
6			<b>See Section 3.0 Clutch System</b>	40	1	612-116	Cable Asm., Throttle – Avenger
7	1	108-84	Washer, Engine Clutch	41	2	103-71	Screw, IHWH T/C 1/4-20 x 1.25 Zn
8	1	112-152	FHSC, 7/16-20 x 4.0" LG	42	1	125-64	Filter, Fuel
9	1	127-137	Drive Belt - 10.5" Cen. Dist	44	4	108-26	Washer, .43 x 1.02 x .09 Zn
10			<b>See Section 3.0 Clutch System</b>	45		112-156	Plug, Oil Drain 3/8-1NPT Hex
11	1	110-03	Key 1/4 x 3/16 x 2.375 RC46	46	1	24 089 46	Spring, Governer (Kohler #)
12	1	M-545016	Screw, Clamp Cable (Kohler #)	47	1	127-49	Spring, Extension
13	1	112-164	HHCS 3/8-16 x 3.5 Gr5 Zn	48	2	103-53	HHCS 3/8-16 x 3.0 Full Thread
14	3	108-06	Lockwasher 3/8 Split Ring Zn	50	1	112-160	HHCS, 7/16-20 x 4.50" Lg
15	1	108-46	Washer .40 x 1.37 x 1.2 Hi- Carbon	51	1	108-58	Washer, .47 x 1.37 x 12 Hi-carbon
16	1	806-35	Frame Ass'y - Power Pack	52	1	66 584 05	ECU (c/w engine)
17	3	117-83	Locknut, Stover 5/8-11 Zn	53	2	112-161	PHMS, 10-24 x 2.5
18	2	811-09	Washer, Square - .64 ID	54	1	24 418 05	02 Sensor
19	2	103-20	HHCS 1/2-13 x 6.5 Gr5 Zn				
20	4	117-29	Locknut, Nylon 3/8-16 Zn				
21	3	112-58	HHCS 5/8-11 x 7.5 Gr5 Zn				
22	2	108-07	Lockwasher 1/2 Split Ring Zn				
23	2	117-06	Nut, Fin Hex 1/2-13 Zn				
24	2	811-15	Washer, Square Lock .64 ID				
25			<b>See Section 1.0 Transmission</b>				
26	2	606-74	Disc, Brake-Splined #60-10T				
27	2	103-18	HHCS 3/8-24 x 1.25 Gr5 Zn				
28	1	110-18	Key 1/4 x 1/4 x 1.75				
29	2	108-18	Washer .40 x 1.37 x .12 Zn				
30	1	12 237 01	Clamp, Cable (Kohler #)				
31	1	24 089 51	Spring, Throttle (Kohler #)				
32			<b>See Section 5.0 Steering &amp; Brake System</b>				
33			<b>See Section 5.0 Steering &amp; Brake System</b>				

# 6.0 Steering & Brake System

# Avenger Parts Manual

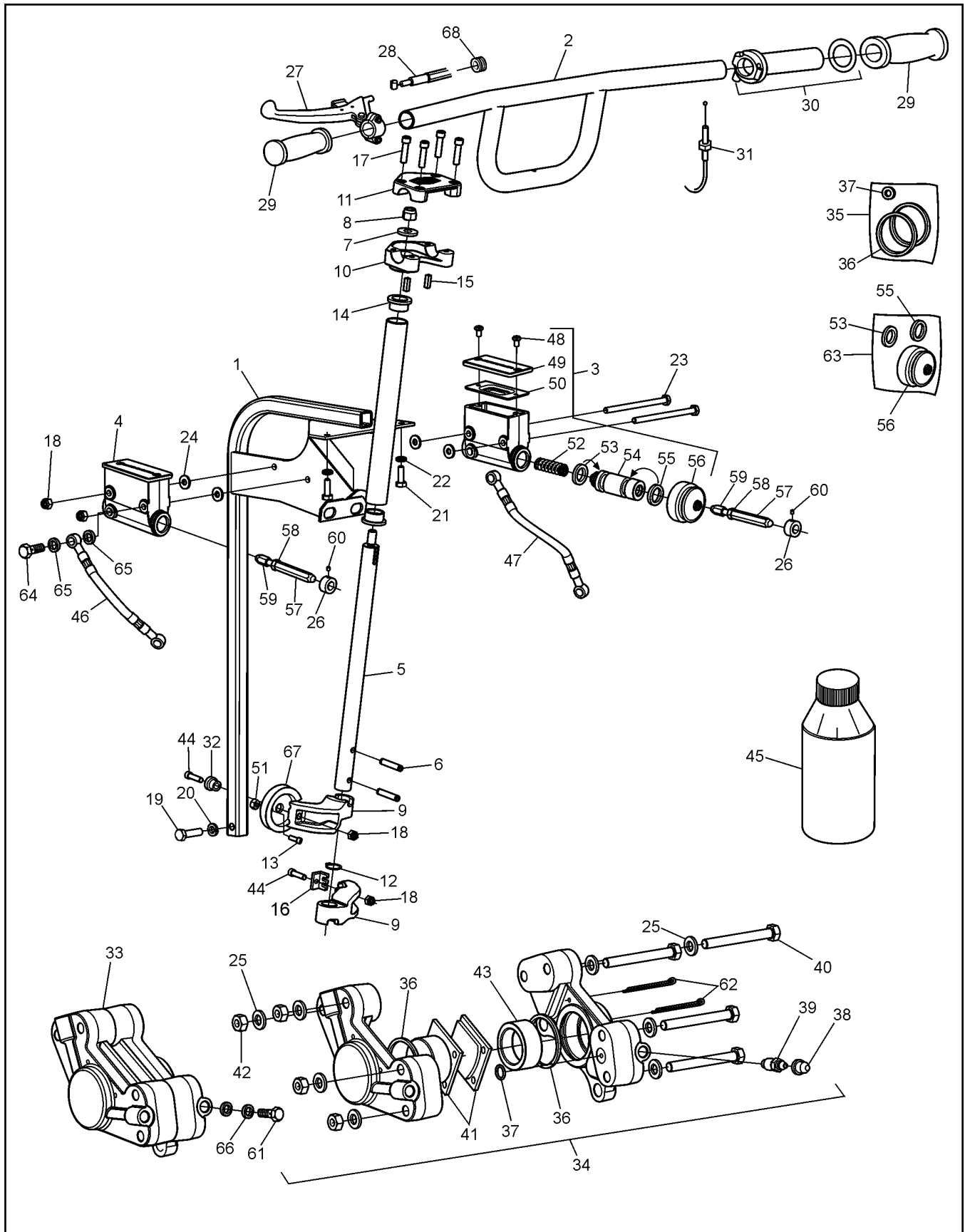

# Avenger Parts Manual

# 6.0 Steering & Brake System

Ref.	Qty.	Part #	Description	Ref.	Qty.	Part #	Description
1	1	612-123	Frame Assembly, Steering Column	41	1	170-03	Pad Set (4), Brake - Non-Asbestos
2	1	612-107	Handlebar Assembly	42	2x4	117-03	Nut, Fin Hex 5/16-18 Zn
3	1	165-08	Master Cylinder, Grimeca - R	43	2x2	168-01	Piston, Knott Caliper
4	1	165-07	Master Cylinder, Grimeca - L	44	2	112-159	BHCS, 1/4-20 x 1.0, Plated
5	1	612-128	Shaft, Steering - Avenger	45		126-19	Fluid, Brake-Silicon Dot 5 - .35L
6	2	104-42	Pin, Spring 1/4 x 1.5"	46	1	163-05	Hose Asm, Hydraulic - Left - Avenger
7	1	108-47	Washer, .39 x .94 x .13 Zn Di-chr	47	1	163-04	Hose Asm, Hydraulic - Right - Avenger
8	1	117-29	Locknut, Nylon 3/8-16 Zn	48	2x2	160-42	Screw, FHMS M5 x 0,8 x 6mm
9	2	612-124	Arm, Steering	49	2x1	168-08	Cover
10	1	612-106	Clamp, Lower Handlebar	50	2x1	168-09	Cover, Rubber
11	1	612-105	Clamp, Upper Handlebar	51	1	117-10	Locknut, 10-24 N/I Zn
12	1	106-07	Ring, Retaining SH-0075PA	52	2x1	162-08	Spring, Comp. 17.3 x 49.3mm
13	1	160-46	SHCS, #10-24 x 3/8"	53	2x1		Seal, Primary, 19mm (See Ref. 63)
14	2	105-16	Bushing, Oilite - 3/4 x 1/2	54	2x1	168-10	Piston 19mm dia.
15	2	110-17	Key, 3/16 x 3/16 x .625	55	2x1		Seal, Secondary, 19mm (See Ref. 63)
16	1	128-24	Retainer, Handbrake Cable	56	2x1		Boot, Rubber (See Ref. 63)
17	4	112-47	SHCS, 1/4-20 x 1.0 Zn	57	2	812-30	Pin, Female
18	4	117-27	Locknut, Nylon 1/4-20 Zn	58	2	117-03	Nut, Fin Hex 1/4-20 Zn
19	1	103-38	HHCS 5/16-18 x 1.25 Gr5 Zn	59	2	812-31	Fin, Male
20	1	108-05	Lockwasher 5/16 Split-Ring Zn	60	2	112-02	SHSS 10-24x1/4 Knurl Cup PT, PL
21	2	112-04	HHCS 1/4-20 x 3/4 Gr2 Zn	61	2	160-45	Bolt, Banjo
22	2	108-03	Lockwasher 1/4 Split Ring Zn	62	2x2	168-07	Pin, Cotter 1/8 x 3.00 Zn
23	2	103-66	HHCS, 1/4-20 x 4.0 Gr5 Zn	63	2x1	161-25	O-Ring Kit - Master Cylinder - Grimeca (incl. Ref. 53, 55 & 56)
24	4	108-08	Washer, .28 x .62 x .04 Zn	64	2	160-44	Bolt, Banjo - M10 x 1,0 x 21,0
25	2x8	108-24	Washer, .34 x .70 x .06 Zn	65	4	160-01	Washer, Copper - 1,5 x 10,0 x 14,0
26	2	812-17	Collar	66	4	160-04	Washer, Copper 2.3 x 10.0 x 16.0
27	1	128-17	Lever Assembly, Handbrake, Spring	67	1	165-18	Pulley, Handbrake Cable
28	1	128-21	Cable Assembly, Handbrake	68	1	125-84	Grommet, Rubber
29	2	127-35	Grip, Molded				
30	1	127-81	Throttle Twist Grip				
31	1	612-116	Cable Asm., Throttle - Avenger				
32	1	105-25	Bushing, Flange Oilite FF-310				
33	1	166-10	Caliper, Hydraulic Brake - L w/o pads				
34	1	166-11	Caliper, Hydraulic Brake - R w/o pads				
35	2	161-05	O-ring Kit, Knott Caliper				
36	2		Seal, Piston				
37	2		Seal, Rubber				
38	2x1	168-20	Plug, Rubber				
39	2x1	168-02	Screw, Bleeding, Knott Caliper				
40	2x4	112-154	SHCS, 5/16-18 x 2.75 Zn				

# 7.0 Parking Brake

# Avenger Parts Manual

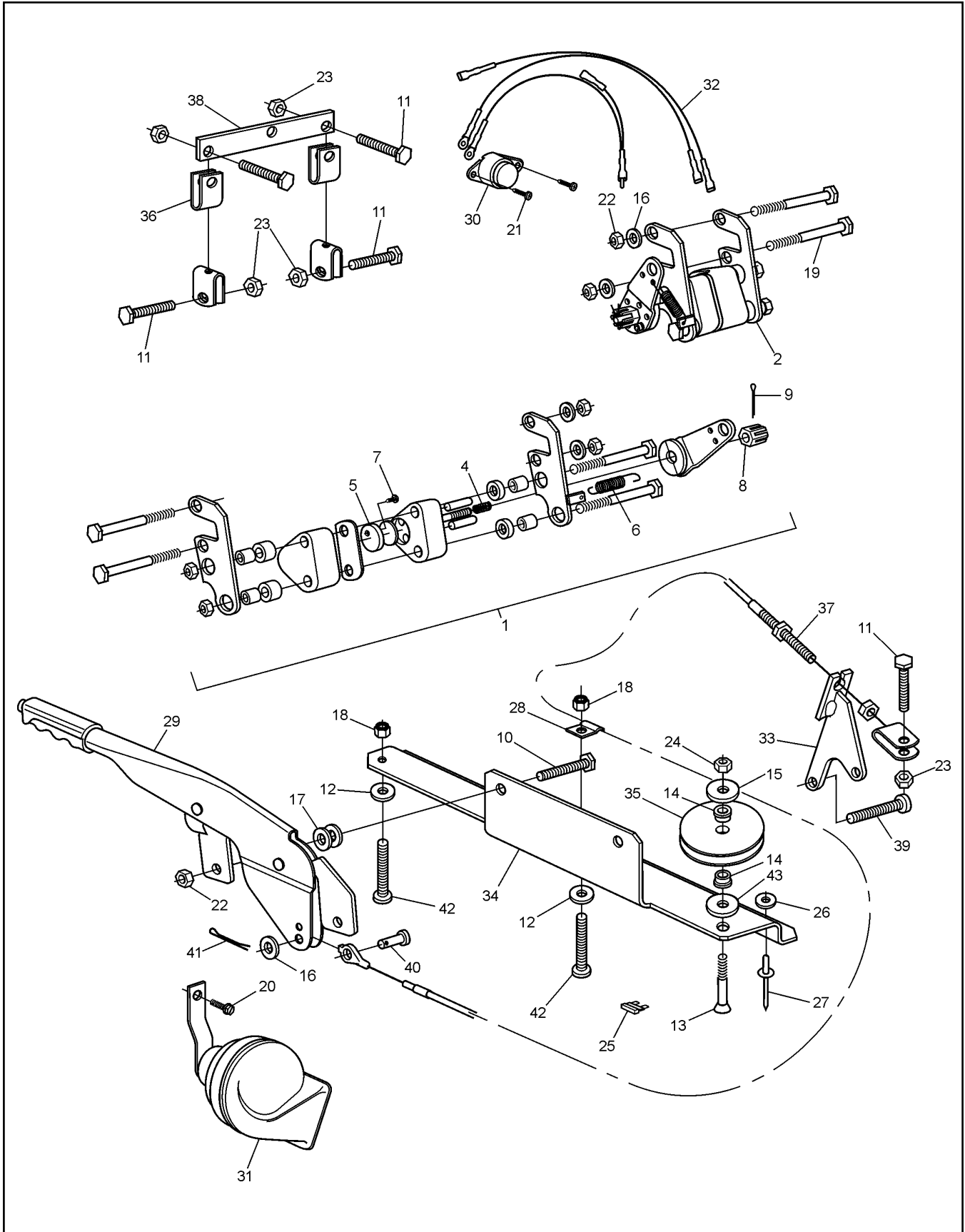

Ref.	Qty.	Part #	Description
1	1	850-96	Caliper Ass'y, LH, Parking Brake
2	1	850-97	Caliper Ass'y, RH, Parking Brake
3	1	850-98	Kit, Service, Parking Brake includes Ref. 4 - 9
4	1		Cam Tension Spring (compression)
5	1		Left & Right Brake Pads
6	1		Cam Arm Spring (tension)
7	1		Brake Pad Retaining Screw
8	1		Castle Nut
9	1		Cotter Pin
10	2	103-06	HHCS 5/16-18x1.0 Gr5 Zn
11	5	103-08	HHCS 1/4-20x1.0 Zn
12	2	108-42	Washer .21x1.0x.06 Zn
13	1	103-100	FHSC, 3/8-16 x 1-1/2 Zn
14	2	105-18	Bushing, Oilite - 3/8x1/4
15	1	108-15	Washer .42 x .81 x .05 Zn
16	21	108-24	Washer .34x.70x.06 Zn
17	4	108-47	Washer .39x.94x.13 Zn Di-Chro
18	2	117-10	Locknut, 10-24 N/I Zn
19	4	112-132	HHCS 5/16-18 x 3.25 Gr5 Zn
20	1	112-19	Screw,IHWH T/C Slot 1/4-20x1/2
21	2	112-56	T/S Pan Head Phil #10x3/4 A Zn
22	6	117-21	Locknut, Nylon 5/16-18 Zn
23	5	117-27	Locknut, Nylon 1/4-20 Zn
24	1	117-29	Locknut, Nylon 3/8-16 Zn
25	1	118-52	Fuse, 10A 2-Prong (AT010)
26	4	120-04	Washer .19x.50x.08 Zn
27	4	120-09	Rivet - 3/16 x 1.0 Black
28	1	128-13	Clip, Conduit-Anti
29	1	809-147	Lever, Parking Brake
30	1	848-86	Button, Horn
31	1	848-87	Horn, Electric
32	1	848-88	Wire Harness, Horn
33	1	850-72	Bracket Asm, Parking/Brake
34	1	850-78	Bracket, Parking Lever
35	1	850-79	Pulley, Parking Brake Cable
36	2	850-80	Cable, Parking Brake Equalizer
37	1	850-81	Cable, Parking Brake
38	1	850-82	Flat Bar, Equalizer
39	1	112-143/P1	SHCS 5/16x1.25 Zn
40	1	104-27	Pin, Clevis 5/16x.75" Zn
41	1	100-100	Pin, Cotter 1/8x3/4 Zn
42	2	112-174	RHMS 10-24 x 1.75 Zn
43	1	108-35	Washer .53 x 1.06 x .09 Zn

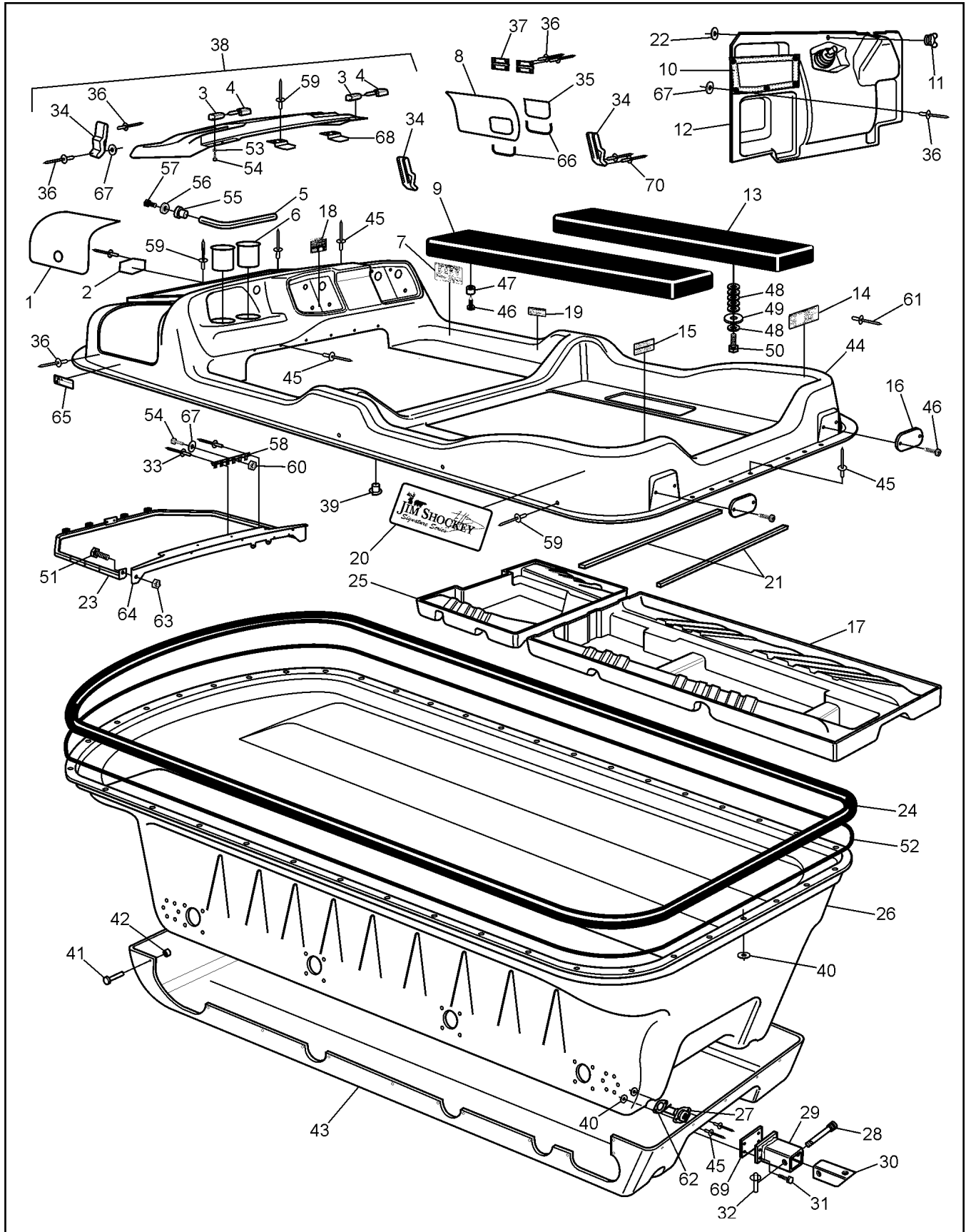



# Avenger Parts Manual

# 8.0 Vehicle Body & Firewall

Ref.	Qty.	Part #	Description	Ref.	Qty.	Part #	Description
1	1	707-43	Screen - Exhaust - Avenger	40	86	120-04	Washer .19 x .50 x .08 Zn
2	1	601-44	Nameplate, "Argo"	41	32	120-27	Pin, Magna Grip
3	2	127-45B	Knuckle, Hinge	42	32	120-28	Collar, Magna Grip
4	2	127-45A	Pin, Hinge	43	1	801-51	Skid Plate, 8x8 - Black
5	1	601-101	Tube, Dash Handle	44	1	801-52	Body & Hood, Upper -
6	2	100-109	Cup holder Insert				Avenger (spec. colour) (incl.
7	1	126-68	Plate, Operation				23, 33, 34, 38)
8	1	707-46	Screen, Intake w/cutout	45	109	120-09	Rivet 3/16 x 1 - Black
9	1	608-64	Seat, Rear - Left	46	8	103-48	T/S Pan HD PHIL #10 x 5/8
10	1	100-108	Mesh, Glove Box	47	4	126-79	Bumper, Plastic - Black
11	1	126-10	Wing Stud	48	24	108-25	Washer .31 x .75 x .06 Zn
12	1	803-60	Firewall, Avenger	49	4	603-15	Washer, Plastic 5/16 Hole
13	1	608-65	Seat, Rear - Right	50	4	103-08	HHCS 1/4-20 x 1.0 Zn
14	1	126-67	Plate, Floor Pan	51	2	112-04	HHCS 1/4-20 x 3/4 Gr2 Zn
15	1	127-173	Plate, Vehicle Capacity	52	1	126-60	Vinyl Strip, 1/2" x 1/4" x 37.5'
16	2	127-01	Reflector, Red	53	8	108-59	Lockwasher #10 Int. Tooth Zn
17	1	803-58	Floor Pan, Rear - Avenger	54	9	103-47	HHCS 10-24 x 1/2
18	1	127-141	Label, Caution - Keyswitch	55	1	113-12	Insert, 1/2-13
19	1	126-69	Plate, Fuel	56	1	108-35	Washer .53 x 1.06 x .09 Zn
20	2	127-151	Nameplate - Jim Shockey	57	1	112-151	HHCS 1/2-13 x 1" Gr2 Zn
			Sig.	58	1	613-37	Terminal Strip, Ground
21	2	601-09	Trim, Vinyl - 28"	59	13	120-13	Rivet, 3/16 x 5/8 Black
22	1	126-09	Grommet, Alum. Flattened	60	1	117-10	Locknut, 10-24 N/I Zn
			Half	61	38	120-24	Rivet, 3/32 x 3/8 Alum. (all
23	1	602-49	Frame Ass'y, Hood - Front				plates)
24	1	801-05	Bumper, Vinyl - 8x8	62	2	100-114	Gasket, Drain Plug
25	1	803-59	Floor Pan, Front - Avenger	63	2	117-82	Locknut, Flange 1/4-20 Zn
26	1	801-50	Body, Lower - Avenger	64	1	602-51	Frame Ass'y, Hood - Rear
27	2	100-107	Plug, Drain - Flanged	65	1	127-144	Label, Warning - HOT
28	1	104-13	Pin, Toplink - 3/4 x 2.75	66	2ft	601-107RM	Trim, Vinyl w/adhesive
29	1	616-16	Hitch Assembly	67	6	120-05	Washer, .19 x .50 x .04 Zn
30	1	616-19	Tube, Hitch	68	2	602-52	Clip, Hood - Avenger
31	4	103-61	HHCS 3/8-24 x 1.5 Gr5 Zn	69	1	616-20	Gasket, Rear Hitch
32	1	104-11	Pin, Lynch - Ring				
33	6	120-15	Rivet - 1/8 x 7/16				
34	3	602-56	Latch, Hood - Soft Draw				
35	1	707-47	Screen, Intake Flap				
36	48	120-11	Rivet 5/32 x 9/16 - Black				
37	2	127-162	Hinge, 1" x 1" Painted				
38	1	602-47	Hood Kit - Avenger (spec.				
			colour) (incl. 3, 4, 34, 36, 53,				
			54, 59, 67, 68)				
39	2	117-44	T- Nut 1/4-20 Zn				

# 9.0 Frame and Drive System

# Avenger Parts Manual

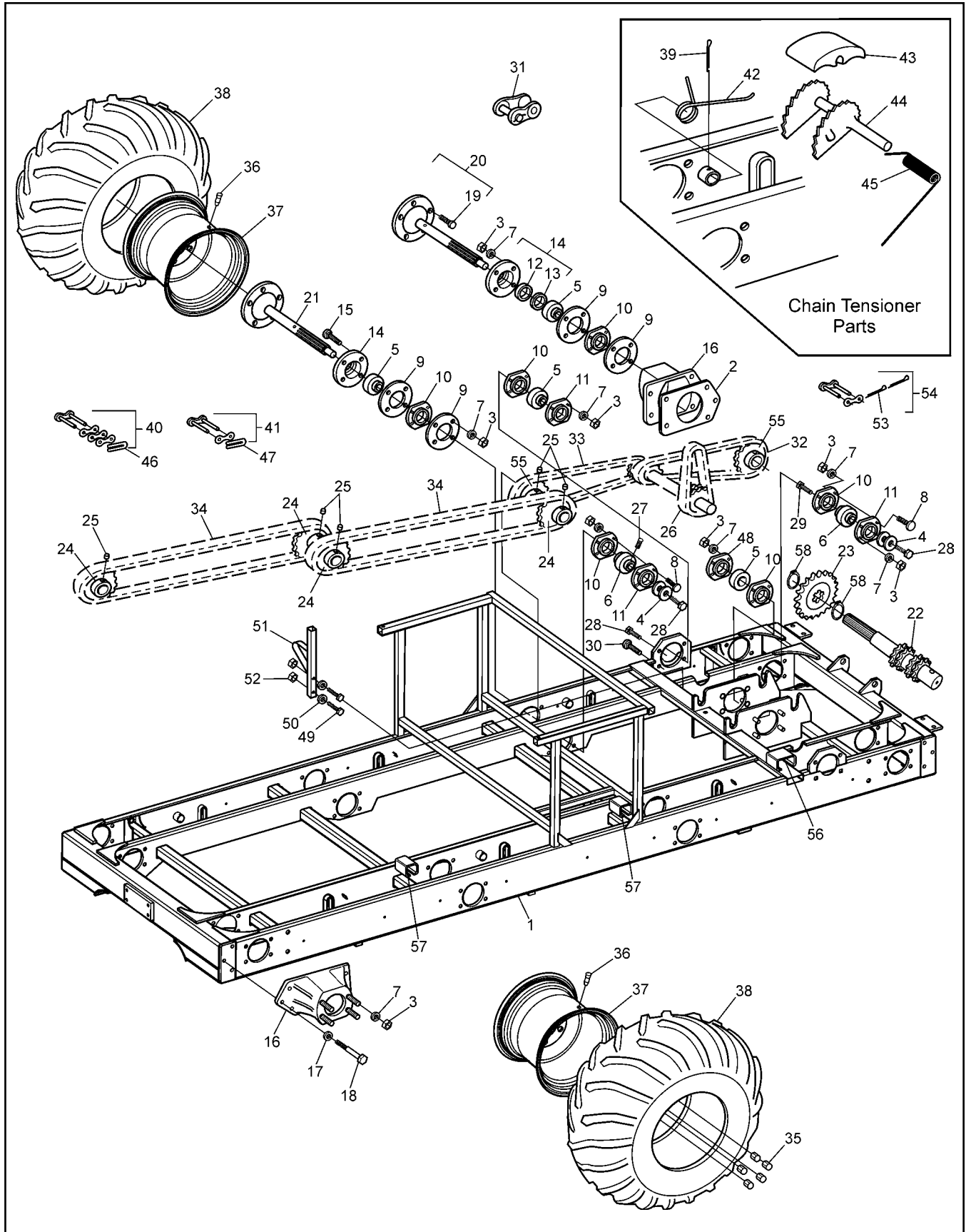

# Avenger Parts Manual

# 9.0 Frame and Drive System

Ref.	Qty.	Part #	Description	Ref.	Qty.	Part #	Description
1	1	804-100	Frame Asm - Avenger	36	8	125-26	Valve, Tire
2	4	606-25	Gasket - Bearing Extension	37	8	127-61C	Rim - 10 x 9 - Charcoal
3	80	117-29	Locknut, Nylon 3/8-16 Zn	38	8	127-100SA	Tire, Rawhide III 25x11.50-9
4	16	108-46	Washer .40 x 1.37 x .12 Hi-Carbon	39	6	100-01	Pin, Cotter 1/8 x 1.50 Zn
5	12	101-35	Bearing, Ball - 1.25	40	1x4	100-96	Con. Link, RC50-2 H.D.
6	8	101-41	Bearing, Ball - 1.0	41	1x4	603-84	Con. Link, RC60-1 H.D.
7	80	108-15	Washer, .42 x .81 x .05 Zn	42	6	127-65	Spring Torsion - 1.16x0.35
8	31	103-88	C/Bolt 3/8-16 x 1.0 Gr5 Zn	43	6	606-44	Slider Block
9	16	605-89	Gasket, Flange - Outer	44	6	606-82	Tensioner Asm, Chain
10	20	605-63	Flange - 4 hole	45	6	127-64	Spring, Torsion - .76 x 1.9
11	10	101-20	Flange, Greasable - 4 hole	46	4	603-95	Spring Clip - RC 50 Closed
12	8	102-14	Seal, Oil 1.25 x 1.75 x 0.188	47	4	603-96	Spring Clip - RC 60 Closed
13	8	102-15	Seal, Oil 1.25 x 1.874 x 0.25	48	2	101-80	Flange, Greaseable - 90 Degree
14	8	605-97	Flange Asm, Outer (incl. Refs. 12 & 13)	49	2	103-97	HHCS 1/4-20 x 1.25
15	16	112-39	C/Bolt 3/8-16 x 1.75 Gr5 Zn	50	4	108-08	Washer .28 x .62 x .07
16	4	810-91	Bearing Extension	51	1	806-43	Support Asm, Firewall
17	20	108-34	Washer .47 x .94 x .06 Zn	52	2	117-27	Locknut, Nylon 1/4-20
18	20	112-150	HHCS 7/16-20 x 1.5 Gr5 Zn	53	4	104-35	Pin, Cotter 2mm x 12mm
19	5x8	103-80	Stud, Wheel 7/16-20 x 1.125 #B271	54	2	603-94	Con. Link, RC60-1 Cotter Pin
20	4	810-73	Axle Asm - Front/Rear (incl. Ref. 19)	55	4	810-28	Sprocket, Double - 24T
21	4	810-75	Axle Asm - Mid (incl. Ref. 19)	56	2	606-43	Slide, Chain - 2-3/4"
22	2	810-59	Shaft, Idler - 11T	57	4	606-42	Slide, Chain - 1.25"
23	2	606-72	Sprocket, Idler S60 x 21T	58	4	107-10	Retaining Ring SH-0125-PA
24	8	606-34	Sprocket, S60 x 19T				
25	10	112-03	SHSS 5/16-18 x 3/8 1/2 DOG, PL				
26	2	803-54	Chain, Idler RC60-1 x 34P (incl. Ref. 41)				
27	2	112-60	SHSS 1/4-28 x 1/2 Cup Pt.				
28	12	112-31	HHCS 3/8-16 x 1.0 2B Gr8 Zn				
29	1	112-163	HHCS 3/8-16 x 2.0 Gr5 Zn				
30	4	112-61	C/Bolt 3/8-16 x 1.25 Gr5 Zn				
31		127-80	Link, Half - RC60 - 1 (opt.)				
32	2	803-55	Chain, RC50-2 x 46P-Front (incl. Ref. 40)				
33	2	803-56	Chain, RC50-2 x 74P-Mid (incl. Ref. 40)				
34	4	803-57	Chain, RC60-1 x 90P-Rear (incl. Ref. 41)				
35	5x8	117-35	Nut, Wheel 7/16-20 Zn				

# 10.0 Fuel System & Seat Assembly Avenger Parts Manual

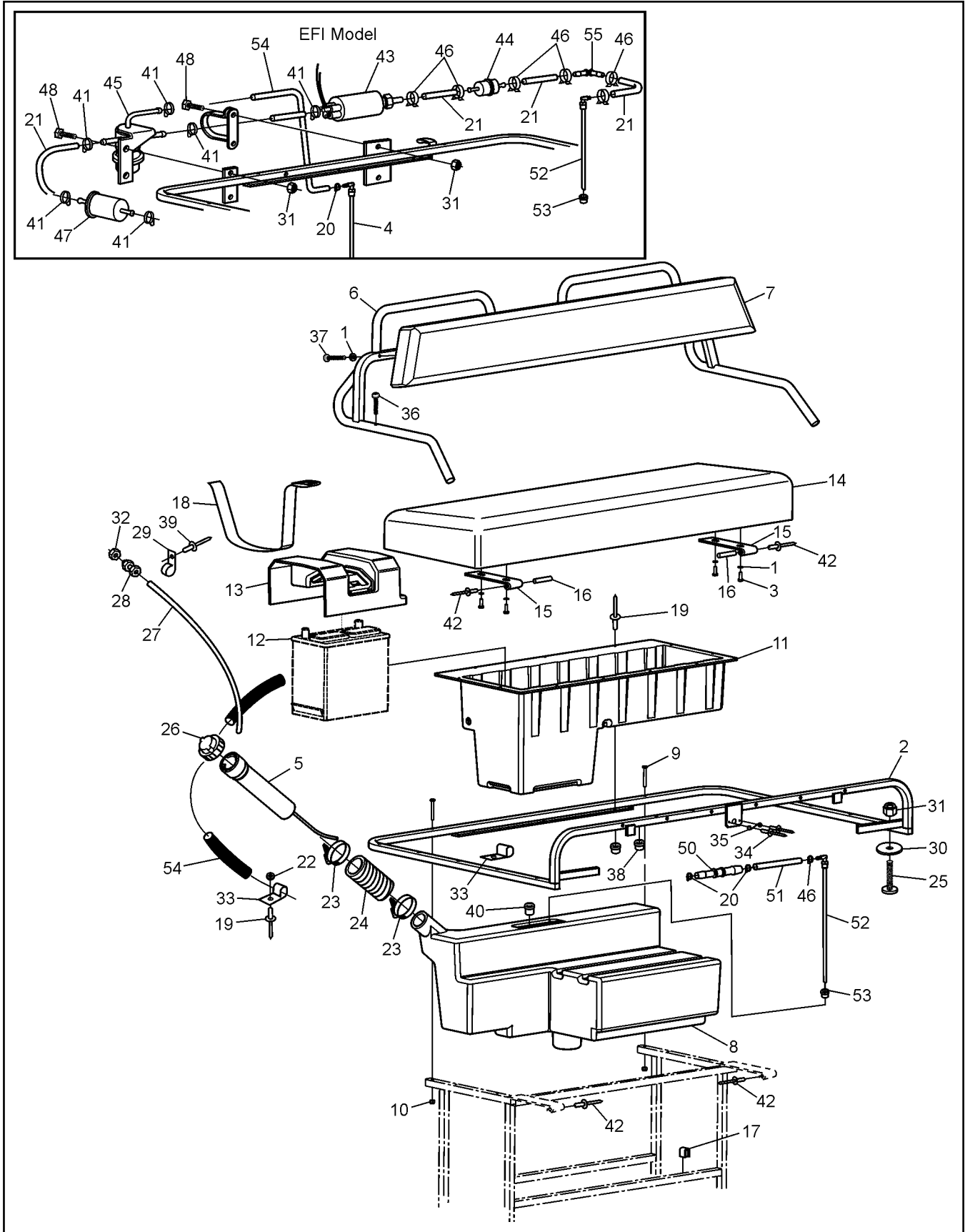

# Avenger Parts Manual 10.0 Fuel System & Seat Assembly

Ref.	Qty.	Part #	Description
1	8	108-03	Lockwasher 1/4 Split Ring Zn
2	1	608-96	Frame Assembly, Seat
3	4	112-04	HHCS 1/4-20x3/4 Gr2 Zn
4	1	608-86	Pick-up, Fuel, 1/4"x 6.75" (Return Tube)
5	1	608-59	Neck Assembly, Vented Filler
6	1	608-76	Frame Assembly, Backrest
7	1	608-39	Back pad Assembly
8	1	608-91	Tank, Fuel - Avg
9	2	103-77	HHCS, 1/4-28 x 2.0
10	2	117-01	Locknut, Nylon 1/4-28 Zn
11	1	608-54	Toolbox
12	1	127-54	<b>See Section 10.0 Electrical System</b>
13	1	608-55	Cover, Battery
14	1	608-88	Seat Assembly, Bench, Thick
15	2	608-81	Hinge, Seat, Bolted
16	2	104-43	Pin, 3/16" x 1-1/8"
17	4	702-06	Foam Cushion
18	1	608-56	Strap, Battery
19	17	120-09	Rivet 3/16x1 - Black
20	4	112-79	Clamp, Hose, 1/2" - Black
21	1	608-69	Hose, Fuel 5/16" ID x 7.5' - Carb
22	8	120-04	Washer .19 x .50 x .08 Zn
23	2	100-12	Clamp, Gear 2.25" HF-36
24	1	125-94	Hose, Filler
25	10	112-07	RHMS 10-24 x 1.50 Zn
26	1	126-46	Cap, Fuel
27	1	127-21	Hose, Vent - 109"
28	1	126-50	Male Connector, 1/4"
29	6	126-94	Clamp, Nylon Wire - 1/4" ID
30	10	108-42	Washer .21 x 1.0x.06 Zn
31	14	117-10	Locknut, Nylon #10-24 Zn
32	1	117-54	Nut, Locking PAL 1/2-20 Zn
33	7	126-93	Clamp, Nylon Wire - 1/2" ID
34	2	120-15	Rivet, 1/8 x 7/16
35	1	126-11	Spring
36	2	112-41	PHMS, Phil 1/4-20 x 1.25 Zn
37	4	103-03	PHMS, Phil 1/4-20 x 1.50 Zn
38	2	117-64	Insert, 1/4-20 Steel Cad Pltg.
39	4	120-13	Rivet, 3/16 x 5/8 Black
40	1	808-123	Plug, Nylon, 1/4 - NPT
41	7	100-101	Clamp, Gear 1/2" HF or MH-4
42	4	120-31	Rivet, 3/16" x 1/4, Open End
43	1	24 393 20	Fuel Pump, EFI
44	1	608-71	Filter, Fuel, 5/16" ID
45	1	24 403 16	Regulator, Fuel Pressure
46	6	112-78	Clamp, Hose, 9/16
47	1	24 050 03	Filter, Fuel Line - EFI - c/w engine
48	4	103-47	HHCS, 10-24 x 1/2
49	4	120-05	Washer, .19 x .5 x .04
50	1	808-133	Reducer, 5/16" to 1/4" Barbed
51	2"	608-69RM	Hose, Fuel - 5/16" ID Carb
52	1	608-89	Pick-up, Fuel, 5/16 x 11.75"
53	1	608-90	Grommet, 5/16" Tube, 3/4" Hole
54	1	608-66	Hose, Fuel 1/4" ID, 80"
55	1	608-94	Fitting, Elbow, 90 Degree, 5/16

# 11.0 Electrical System

# Avenger Parts Manual

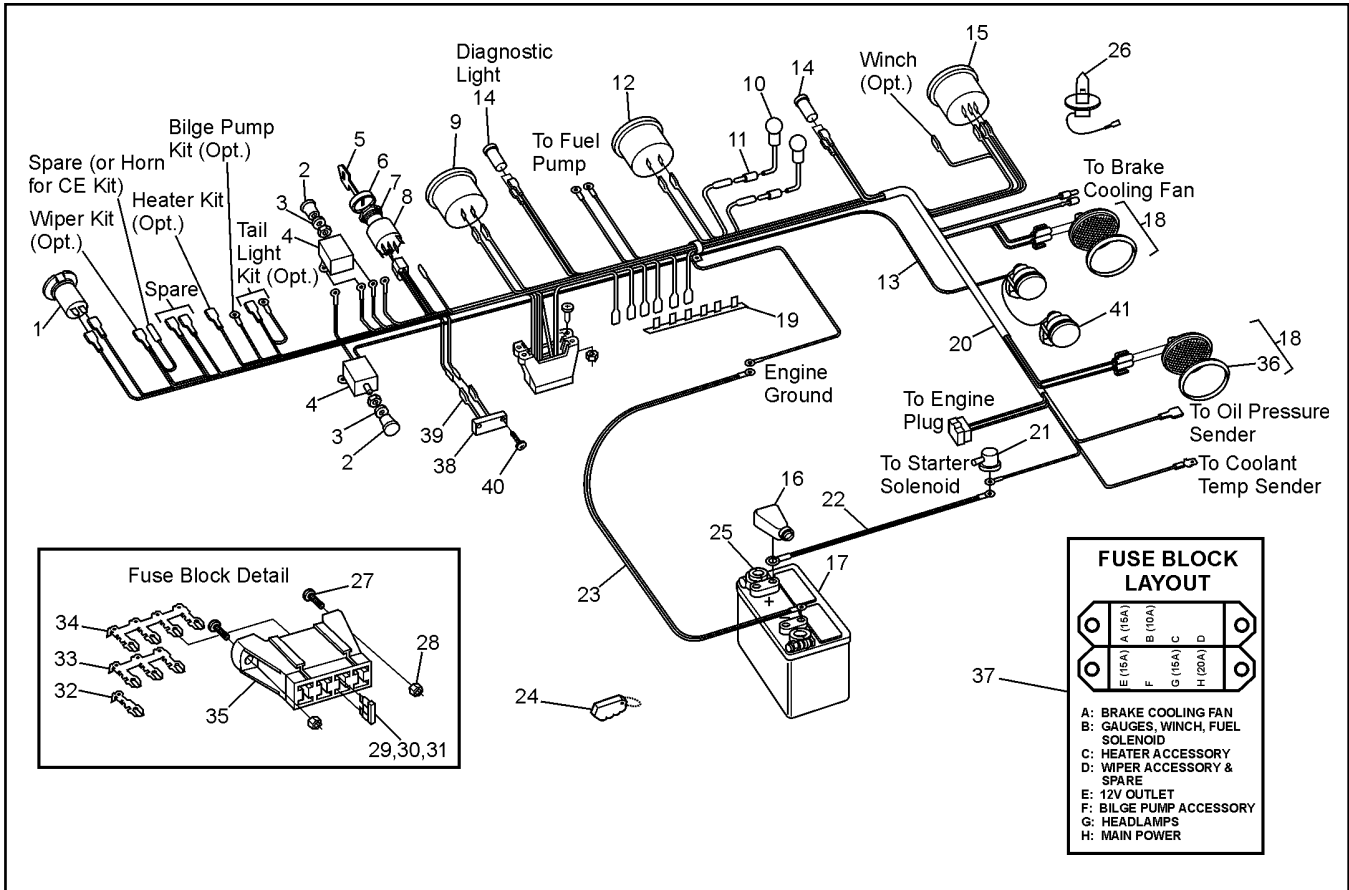

Ref.	Qty.	Part #	Description
1	1	613-90	Outlet, 12 Volt DC
2	2	126-76	Knob, Light - Black
3	2	108-55	Lockwasher 7/16 Ext. Tooth Zn
4	2	100-62	Switch, Light
5	2	127-108	Key, Molded
6	1	127-107	Bezel - Cover, Nut
7	1	127-106	Nut, Flanged - Plastic
8	1	127-105	Switch - Ignition
9	1	632-15	Hourmeter #85005C-22
10	2	634-10	Light Kit, #06215-00 5/8" Dia.
11	3	118-02	Terminal, Male #76-1251
12	1	633-10	Voltmeter #07583-15 (#830EM)
13			<b>See Section 4.0 Brush Guard Kit</b>
14	2	634-08	Light, Indicator
15	1	634-23	Gauge, Water Temp. - Avenger
16	1	127-55	Cap, Battery Terminal - Red
17	1	127-54	Battery, Exide 45-60
18	2	613-92	Headlamp Ass'y - Oval w/Bezel (incl. items 26 & 36)
19	2	613-37	Terminal Strip, Ground
20	1	613-96	Wire Harness, Kohler 25HP
20a	1	613-106	Wire Harness, Kohler 31HP EFI

Ref.	Qty.	Part #	Description
21	1	613-46	Insulator, Terminal (2 ga.)
22	1	613-94	Wire, Positive Battery
23	1	613-95	Wire, Negative Battery
24	1	681-00	FOB, Key - Floating
25	2	127-56	Terminal, Battery Post
26	2	127-46	Bulb, Headlight - Halogen 37W
27	2	112-51	Screw, IHWH T/C #10-24 x 5/8
28	4	117-10	Locknut, Nylon #10-24 Zn
29	1	118-52	Fuse, 10A 2 Prong (AT010)
30	3	118-49	Fuse, 15A 2 Prong (AT015)
31	1	118-53	Fuse, 20A 2 Prong (AT020)
32	9	118-62	Terminal - Fuse, single
33	1	118-63	Terminal - Fuse, triple
34	1	118-61	Terminal - Fuse, quad
35	2	118-60	Block - Fuse, 8 position (4 fuse)
36	2	613-93	Bezel, Headlamp - Avenger
37	1	127-143	Label, Fuse Panel - Kohler
38	1	613-99	Light, Shifter Illumination
39	2	118-69	Terminal, 3/16 Male Blade 22 Ga
40	2	112-139	OHPS T/S #4 x 5/8 Black Zn
41			<b>See Section 4.0 Brush Guard Kit</b>

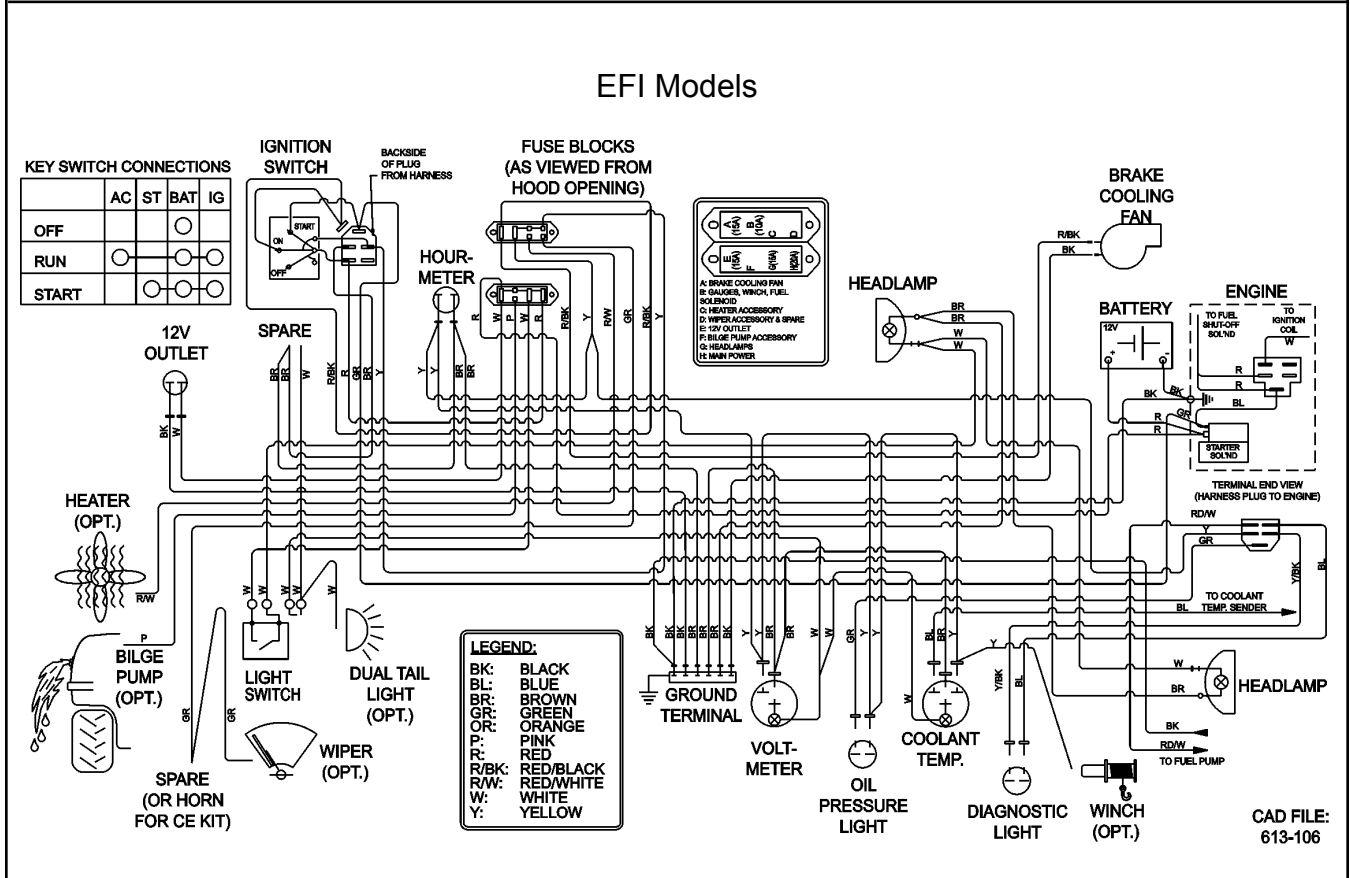
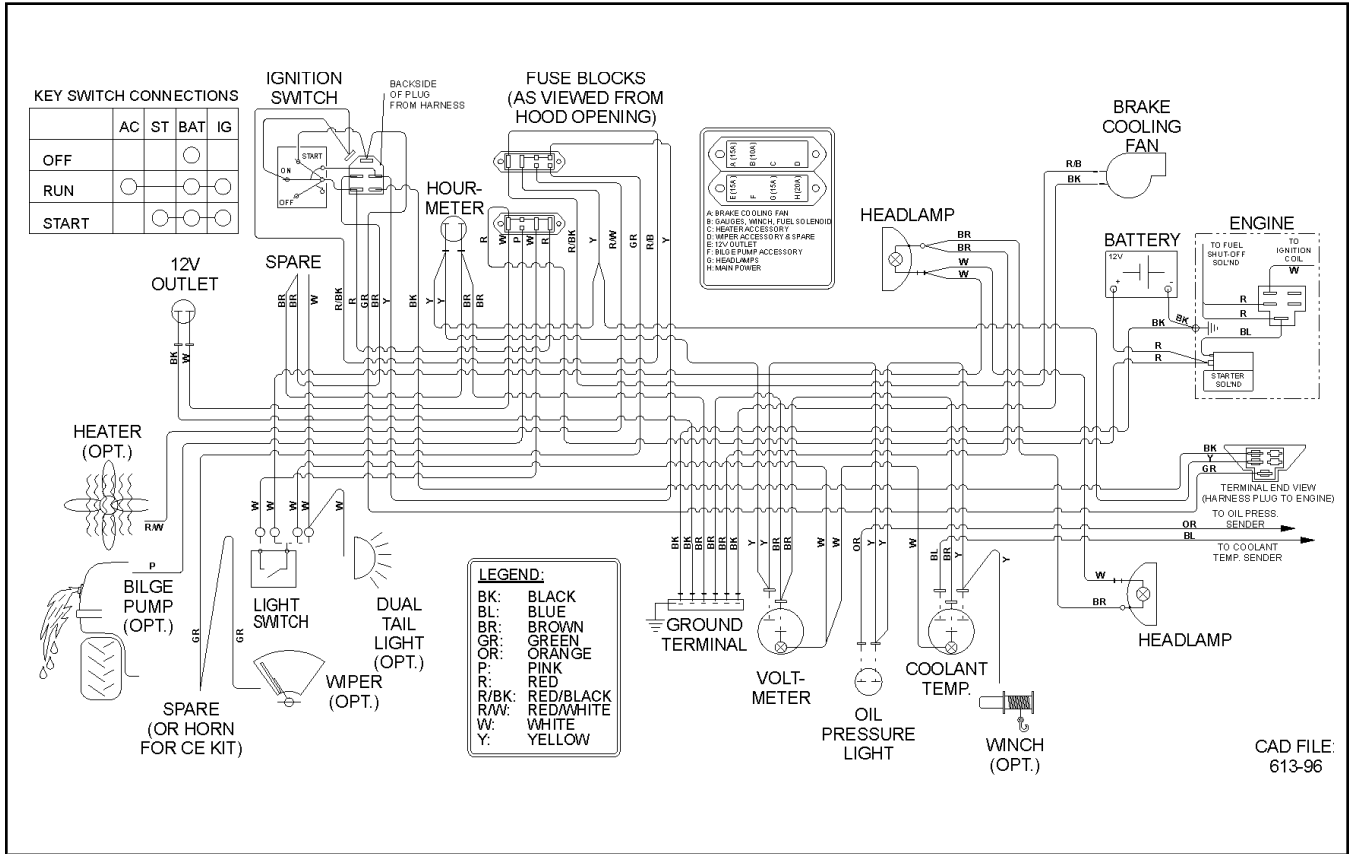

# **ARGO** Products Manufactured by:

## **Ontario Drive & Gear Limited**

220 Bergey Court

New Hamburg, Ontario

Canada N3A 2J5

Phone: (519) 662-2840

Fax: (519) 662-2421

[www.argoatv.com](http://www.argoatv.com)

**ODG** *Dedicated to quality and performance*